

RANGE COMPOSITION

N 700: a range of over 100 models for the professional caterer designed to guarantee the highest level of performance, reliability, energy saving, safety standards and ergonomic operation. These concepts are reflected in the total modularity of the range that ensures numerous configurations, either free-standing, or bridged. N 700 demonstrates how advanced technology can satisfy the needs of the professional caterer. The models detailed on this sheet are gas grills in half and full module ideal for grilling fish and meats.



178094

N 700

GAS LAVA CHAR-GRILL TOPS **ZANUSSI** PROFESSIONAL

FUNCTIONAL AND CONSTRUCTION FEATURES

- ◆ Stainless steel burners. Each burner consists of 3 high power gas rails. The gas burners are protected by stainless steel deflection trays to prevent blockage from foreign objects.
- ◆ Each ½ module has a separate control for the burner with a flame failure device.

- ◆ Worktop in 1,5mm stainless steel. Front panel in stainless steel with Scotch Brite finish.
- ◆ All models have right-angled side edges to allow flush fitting joints between units.
- ◆ Cast-iron grids with frontal draining channel for fat and stainless steel splashguard on three sides. Multi purpose cast iron grids are adjustable in 3 different levels.

- ◆ Multi purpose grids adjust in 3 different levels.
- ◆ IPX4 water protection.
- ◆ Main connections can be via the rear or the base of the unit.
- ◆ All gas appliances are supplied for use with natural gas or LPG. Conversion jets supplied as standard.
- ◆ Not for installation on refrigerated base.

TECHNICAL DATA		
CHARACTERISTICS	MODELS	
	KGG400T 178094	KGG800T 178095
Power supply	Gas	Gas
External dimensions - mm		
width	400	800
depth	700	700
height	250	250
Power - kW		
gas	7	14
Net weight - kg.	32	64
INCLUDED ACCESSORIES		
CAST IRON GRID FOR GRILL TOPS	1	2

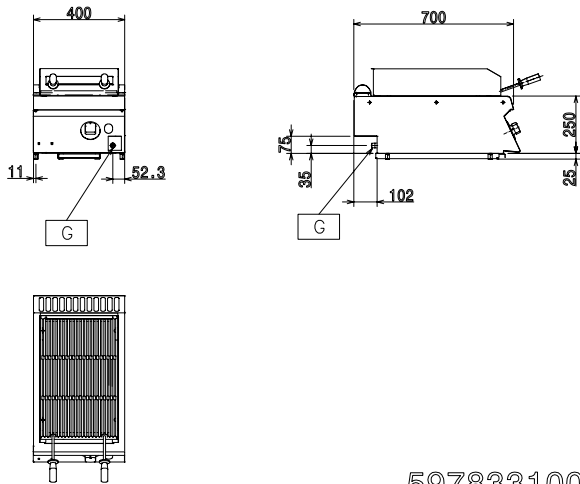

597833100

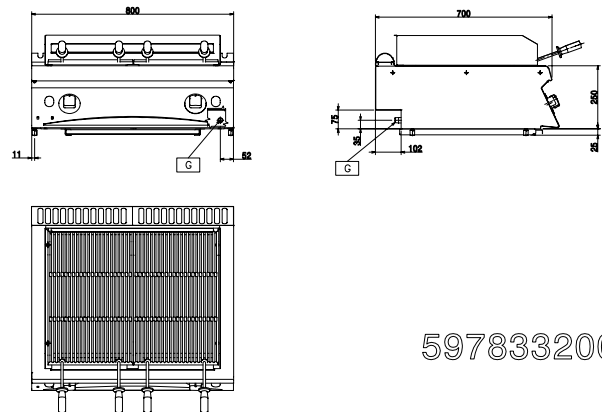

597833200

LEGEND

	KGG400T 178094	KGG800T 178095
G - Gas connection	1/2"	1/2"

OPTIONAL ACCESSORIES

ACCESSORIES	MODELS	
	KGG400T 178094	KGG800T 178095
2 SIDE COVERING PANELS FOR TOP-D=700MM	206277	206277
CHIMNEY COVER 400MM CLOSED	206269	
CHIMNEY COVER 800MM CLOSED		206271
CHIMNEY UPSTAND 400MM	206303	
CHIMNEY UPSTAND 800MM		206304
DRAUGHT DIVERTER WITH 120 MM DIAMETER	206126	
DRAUGHT DIVERTER WITH 150 MM DIAMETER		206132
FLUE CONDENSER FOR 1 MODULE DIAM.150MM		206246
FLUE CONDENSER FOR 1/2 MOD. DIAM.120MM	206310	
MATCHING RING FOR FLUE CONDENSER 150DIAM		206133
MATCHING RING-FLUE CONDENSER 120-130DIAM	206127	
PRESSURE REGULATOR FOR GAS UNITS	927225	927225
S/S GRID+DRAINAGE CHANNELS F. GRILL TOPS	921612	921612
SCRAPER FOR GRID W/DRAINAGE - GRILL TOPS	921614	921614



www.zanussiprofessional.com