

## RANGE COMPOSITION

N 700: a range of over 100 models for the professional caterer designed to guarantee the highest level of performance, reliability, energy saving, safety standards and ergonomic operation. These concepts are reflected in the total modularity of the range that ensures numerous configurations, either free-standing or bridged. N 700 demonstrates how advanced technology can satisfy the needs of the professional caterer. The models detailed on this sheet are 7 gas fry tops in full module version with smooth or 2/3 smooth and 1/3 ribbed plates in stainless steel or chromed steel.



178055

## N 700

### FULL MODULE GAS FRY TOPS **ZANUSSI** PROFESSIONAL

## FUNCTIONAL AND CONSTRUCTION FEATURES

◆ Safety thermostat on models with thermostatic control (temperature markings in °C). Piezo ignition.

◆ Worktop in 1,5mm stainless steel. Front panel in stainless steel with Scotch Brite finish.

◆ All models have right-angled side edges to allow flush fitting joints between units.

TECHNICAL DATA							
CHARACTERISTICS	MODELS						
	KRG800 178048	KRG813 178049	KRG800C 178050	KRG813C 178057	KRGV800 178054	KRGV813 178055	KRGV800C 178056
Power supply	Gas	Gas	Gas	Gas	Gas	Gas	Gas
External dimensions - mm							
width	800	800	800	800	800	800	800
depth	700	700	700	700	700	700	700
height	250	250	250	250	850	850	850
Cooking surface							
material	Mild Steel	Mild Steel	Chromium Plated	Chromium Plated	Mild Steel	Mild Steel	Chromium Plated
Thermostatic valve			●	●			●
Cooking surface dimensions - mm							
width	730	730	730	730	730	730	730
depth	540	540	540	540	540	540	540
Working temperature - min/max - °C	200, 400	200, 400	130, 300	130, 300	200, 400	200, 400	130, 300
Storage cupboard - mm							
width					680	680	680
depth					640	640	640
height					420	420	420
Power - kW							
gas	14	14	14	14	14	14	14
Net weight - kg.	70	70	70	70	80	80	80
Smooth cooking surface	●		●		●		●
Smooth/Ribbed cooking surface		●		●		●	
INCLUDED ACCESSORIES							
SCRAPER FOR RIBBED PLATE FRY TOP				1			
SCRAPER FOR SMOOTH PLATE FRY TOP			1	1			1

- ◆ Very quick heat-up time to maximum temperature.
- ◆ Full module units have separate controls for each ½ module of the cooking surface.
- ◆ Cooking surface in mild steel or chromed: available smooth and ribbed for optimum grilling results.
- ◆ The standard Fry Top cooking plate is manufactured from 15mm thick special mild steel for even temperature distribution. Ideal for grilling, browning and the radiant heat allows thicker cuts of meat to be cooked perfectly.
- ◆ The chromium surface means no absorption of cooking juices into the plate resulting in higher output of product and more flexibility. Very little energy is lost to the kitchen environment due to the reflective qualities of the chromium surface, making the work area more comfortable.
- ◆ On the cooking surface there is a large drain hole to drain fat into a 2-lt grease collection drawer (for top models) or into a 3,5-lt grease collection tray, extractable from open base (for models on base).
- ◆ Splashback in stainless steel included as standard.
- ◆ IPX4 water protection.
- ◆ Main connections can be via the base or the rear of the unit.
- ◆ All top models can be easily mounted on refrigerated base, open base cupboards or bridging supports.
- ◆ All top models provided with service duct to facilitate installation.
- ◆ All gas appliances are supplied for use with natural gas or LPG. Conversion jets supplied as standard.

OPTIONAL ACCESSORIES ACCESSORIES	MODELS						
	KRG800 178048	KRG813 178049	KRG800C 178050	KRG813C 178057	KRGV800 178054	KRGV813 178055	KRGV800C 178056
2 DRAWERS FOR OPEN BASE					206255	206255	206255
2 SIDE COVERING PANELS FOR TOP-D=700MM	206277	206277	206277	206277	206277	206277	206277
2 SIDE COVERING PANELS H=700 D=700					206000	206000	206000
2 SIDE KICKING STRIPS-CONCRETE INSTALL.					206265	206265	206265
2 SUPPORTS+RUNNERS FOR 4 GN 1/1&2/1 CONT					206244	206244	206244
4 FEET FOR CONCRETE INSTALLATION					206210	206210	206210
4 WHEELS (2 WITH BRAKE)					206188	206188	206188
CENTRAL SUPPORT FOR 800MM/1200MM CUPB.					206245	206245	206245
CHIMNEY COVER 800MM OPEN-LARGE CHIMNEY	206273	206273	206273	206273	206273	206273	206273
ELECTRIC HEATING KIT FOR CUPBOARDS					206259	206259	206259
FLANGED FEET KIT					206136	206136	206136
FRONT.KICK.STRIP F.CONCRETE INST.1000 MM					206150	206150	206150
FRONT.KICK.STRIP F.CONCRETE INST.1200 MM					206151	206151	206151
FRONT.KICK.STRIP F.CONCRETE INST.1600 MM					206152	206152	206152
FRONT.KICK.STRIP F.CONCRETE INST.200 MM					206146	206146	206146
FRONT.KICK.STRIP F.CONCRETE INST.400 MM					206147	206147	206147
FRONT.KICK.STRIP F.CONCRETE INST.800 MM					206148	206148	206148
FRONTAL HANDRAIL 1200 MM	206191	206191	206191	206191	206191	206191	206191
FRONTAL HANDRAIL 1600 MM	206192	206192	206192	206192	206192	206192	206192
FRONTAL HANDRAIL 400 MM	206166	206166	206166	206166	206166	206166	206166
FRONTAL HANDRAIL 800 MM	206167	206167	206167	206167	206167	206167	206167
FRONTAL KICKING STRIP 1000 MM					206177	206177	206177
FRONTAL KICKING STRIP 1200 MM					206178	206178	206178
FRONTAL KICKING STRIP 1600 MM					206179	206179	206179
FRONTAL KICKING STRIP 200 MM					206174	206174	206174
FRONTAL KICKING STRIP 400 MM					206175	206175	206175
FRONTAL KICKING STRIP 800 MM					206176	206176	206176
LARGE HANDRAIL(PORIONING SHELF)400 MM	206185	206185	206185	206185	206185	206185	206185
LARGE HANDRAIL(PORIONING SHELF)800 MM	206186	206186	206186	206186	206186	206186	206186
LEFT SIDE DOOR FOR OPEN BASE CUPBOARD					206195	206195	206195
PAIR OF SIDE KICKING STRIPS					206249	206249	206249
PRESSURE REGULATOR FOR GAS UNITS	927225	927225	927225	927225	927225	927225	927225
RIGHT AND LEFT SIDE HANDRAILS	206240	206240	206240	206240	206240	206240	206240
RIGHT SIDE DOOR FOR OPEN BASE CUPBOARD					206194	206194	206194
SCRAPER FOR RIBBED PLATE FRY TOP		164257				164257	
SCRAPER FOR SMOOTH PLATE FRY TOP	164255	164255			164255	164255	
SIDE WALL FOR CUPBOARD					206252	206252	206252
SUPPORT FOR "BRIDGE" SYSTEM 1000 MM	206138	206138	206138	206138			
SUPPORT FOR "BRIDGE" SYSTEM 1200 MM	206139	206139	206139	206139			
SUPPORT FOR "BRIDGE" SYSTEM 1400 MM	206140	206140	206140	206140			
SUPPORT FOR "BRIDGE" SYSTEM 1600 MM	206141	206141	206141	206141			
SUPPORT FOR "BRIDGE" SYSTEM 400 MM	206154	206154	206154	206154			
SUPPORT FOR "BRIDGE" SYSTEM 800 MM	206137	206137	206137	206137			
WATER COLUMN EXTENSION FOR 700 LINE	206291	206291	206291	206291	206291	206291	206291
WATER COLUMN WITH SWIVEL ARM	206289	206289	206289	206289	206289	206289	206289



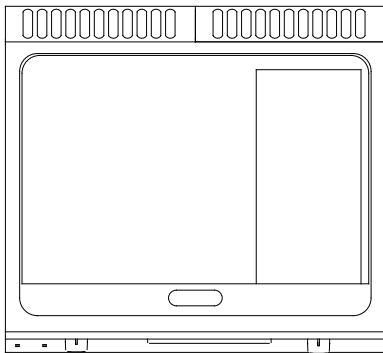
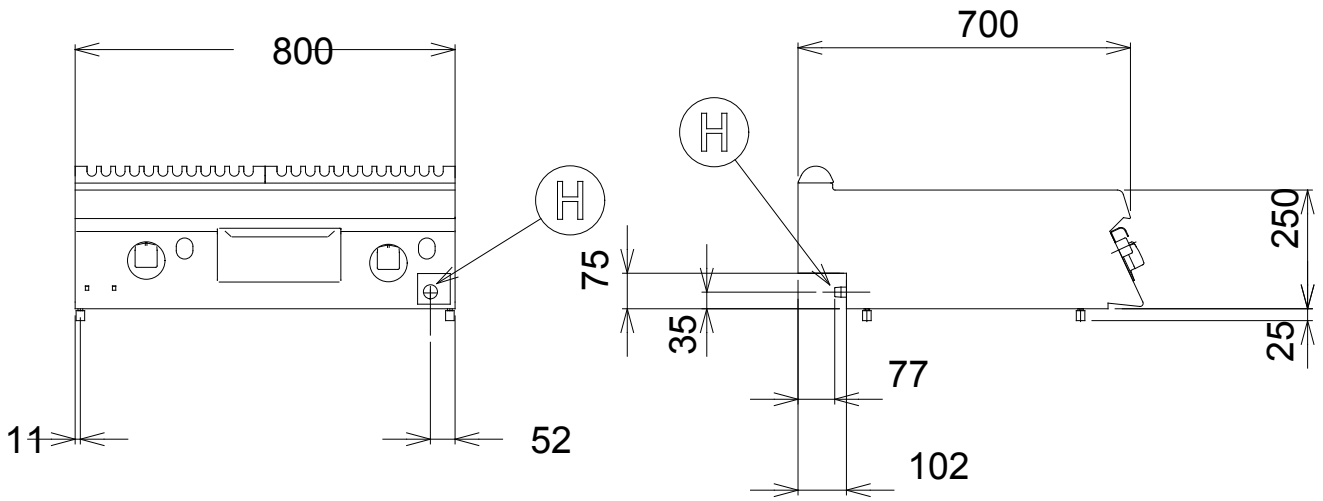

597826100

LEGEND

	KRG800 178048	KRG813 178049	KRG800C 178050	KRG813C 178057
H - Gas connection	1/2"	1/2"	1/2"	1/2"



www.zanussiprofessional.it

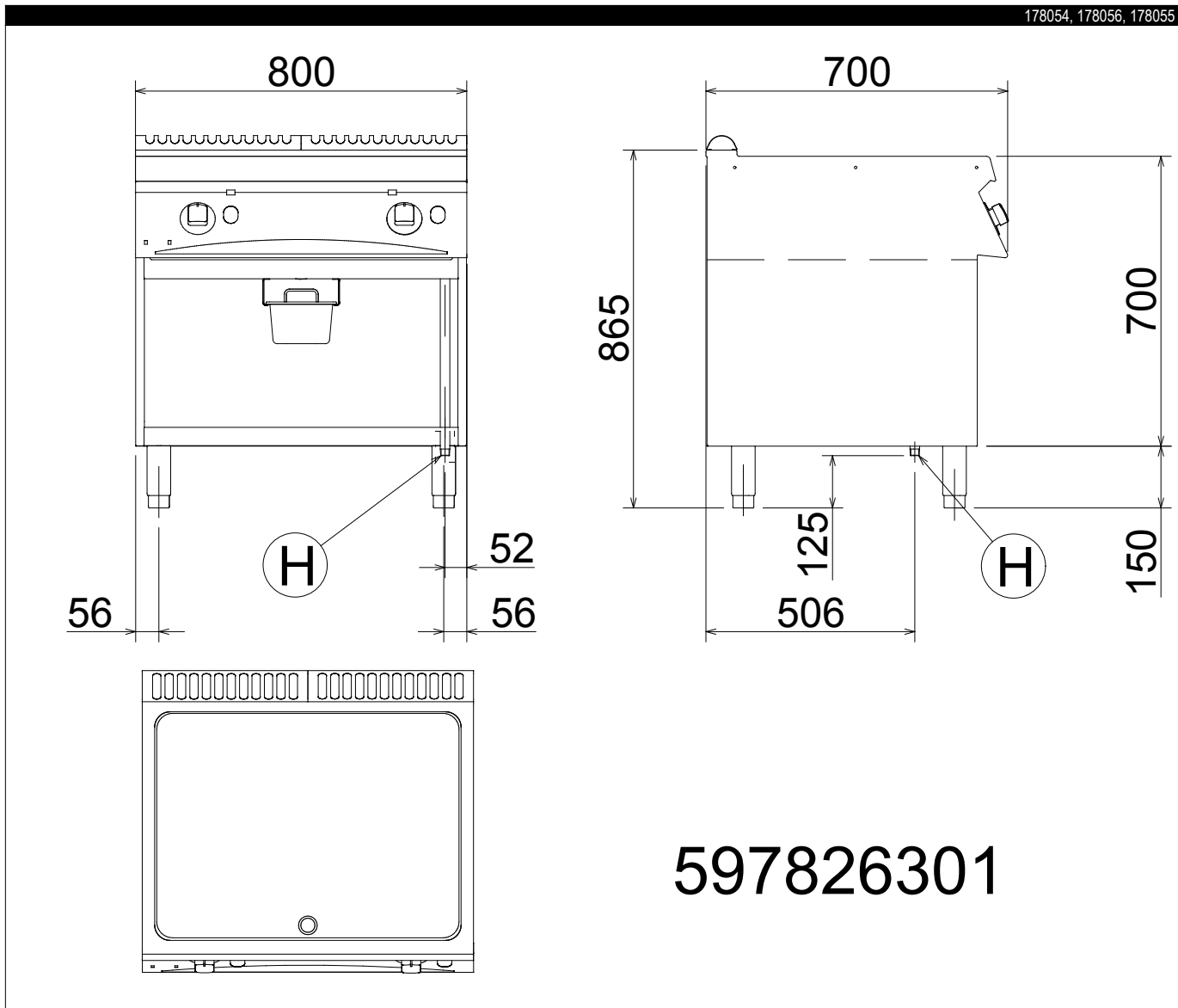

597826301

LEGEND			
	KRGV800 178054	KRGV813 178055	KRGV800C 178056
H - Gas connection	1/2"	1/2"	1/2"



www.zanussiprofessional.it