

RANGE COMPOSITION

N 700: a range of over 100 models for the professional caterer designed to guarantee the highest level of performance, reliability, energy saving, safety standards and ergonomic operation. These concepts are reflected in the total modularity of the range that ensures numerous configurations, either free-standing or bridged. N 700 demonstrates how advanced technology can satisfy the needs of the professional caterer. The models detailed on this sheet are gas fry tops in ½ module version with smooth or ribbed plates in mild steel or chromed steel.



178045

N 700

HALF MODULE GAS FRY TOPS **ZANUSSI** PROFESSIONAL

FUNCTIONAL AND CONSTRUCTION FEATURES

◆ Safety thermostat on models with thermostatic control (temperature markings in °C). Piezo ignition.

◆ Worktop in 1,5mm stainless steel. Front panel in stainless steel with Scotch Brite finish.

◆ All models have right-angled side edges to allow flush fitting joints between units.
◆ Very quick heat-up time to maximum temperature.

TECHNICAL DATA						
CHARACTERISTICS	MODELS					
	KRG400 178045	KRG401 178046	KRG400C 178047	KRGV400 178051	KRGV401 178052	KRGV400C 178053
Power supply	Gas	Gas	Gas	Gas	Gas	Gas
Type of gas burner control	Cock	Cock	Thermostatic valve	Cock	Cock	Thermostatic valve
External dimensions - mm						
width	400	400	400	400	400	400
depth	700	700	700	700	700	700
height	250	250	250	850	850	850
Cooking surface						
material	Mild Steel	Mild Steel	Chromium Plated	Mild Steel	Mild Steel	Chromium Plated
Cooking surface dimensions - mm						
width	330	330	330	330	330	330
depth	540	540	540	540	540	540
Working temperature - min/max - °C	200, 400	200, 400	130, 300	200, 400	200, 400	130, 300
Storage cupboard - mm						
width				330	330	330
depth				640	640	640
height				420	420	420
Power - kW						
gas	7	7	7	7	7	7
Net weight - kg.	40	40	40	50	50	50
Smooth cooking surface	●		●	●		●
Ribbed cooking surface		●			●	
INCLUDED ACCESSORIES						
SCRAPER FOR SMOOTH PLATE FRY TOP			1			1

- ◆ Cooking surface in mild steel or chromed: available smooth or ribbed for optimum grilling results.
- ◆ The standard Fry Top cooking plate is manufactured from 15mm thick special mild steel for even temperature distribution. Ideal for grilling, browning and the radiant heat allows thicker cuts of meat to be cooked perfectly.

- ◆ The chromium surface means no absorption of cooking juices into the plate resulting in higher output of product and more flexibility. Very little energy is lost to the kitchen environment due to the reflective qualities of the chromium surface, making the work area more comfortable.
- ◆ On the cooking surface there is a large drain hole to drain fat into a 1-lt grease collection drawer (for top models) or into a 3,5-lt grease collection tray, extractable from open

- base (for models on base).
- ◆ Splashback in stainless steel included as standard.
- ◆ IPX4 water protection.
- ◆ Main connections can be via the rear or the base of the unit.
- ◆ All top models can be easily mounted on open base cupboards or bridging supports.
- ◆ All top models provided with service duct to facilitate installation.
- ◆ All gas appliances are supplied for use with natural gas or LPG. Conversion jets supplied as standard.

OPTIONAL ACCESSORIES						
ACCESSORIES	MODELS					
	KRG400 178045	KRG401 178046	KRG400C 178047	KRGV400 178051	KRGV401 178052	KRGV400C 178053
2 DRAWERS FOR OPEN BASE				206255	206255	206255
2 SIDE COVERING PANELS FOR TOP-D=700MM	206277	206277	206277	206277	206277	206277
2 SIDE COVERING PANELS H=700 D=700				206000	206000	206000
2 SIDE KICKING STRIPS-CONCRETE INSTALL.				206265	206265	206265
2 SUPPORTS+RUNNERS FOR 4 GN 1/1&2/1 CONT				206244	206244	206244
4 FEET FOR CONCRETE INSTALLATION				206210	206210	206210
4 WHEELS (2 WITH BRAKE)				206188	206188	206188
CHIMNEY COVER 400MM OPEN	206284	206284	206284	206284	206284	206284
ELECTRIC HEATING KIT FOR CUPBOARDS				206259	206259	206259
FLANGED FEET KIT				206136	206136	206136
FRONT.KICK.STRIP F.CONCRETE INST.1000 MM				206150	206150	206150
FRONT.KICK.STRIP F.CONCRETE INST.1200 MM				206151	206151	206151
FRONT.KICK.STRIP F.CONCRETE INST.1600 MM				206152	206152	206152
FRONT.KICK.STRIP F.CONCRETE INST.200 MM				206146	206146	206146
FRONT.KICK.STRIP F.CONCRETE INST.400 MM				206147	206147	206147
FRONT.KICK.STRIP F.CONCRETE INST.800 MM				206148	206148	206148
FRONTAL HANDRAIL 1200 MM	206191	206191	206191	206191	206191	206191
FRONTAL HANDRAIL 1600 MM	206192	206192	206192	206192	206192	206192
FRONTAL HANDRAIL 400 MM	206166	206166	206166	206166	206166	206166
FRONTAL HANDRAIL 800 MM	206167	206167	206167	206167	206167	206167
FRONTAL KICKING STRIP 1000 MM				206177	206177	206177
FRONTAL KICKING STRIP 1200 MM				206178	206178	206178
FRONTAL KICKING STRIP 1600 MM				206179	206179	206179
FRONTAL KICKING STRIP 200 MM				206174	206174	206174
FRONTAL KICKING STRIP 400 MM				206175	206175	206175
FRONTAL KICKING STRIP 800 MM				206176	206176	206176
LARGE HANDRAIL(PORTIONING SHELF)400 MM	206185	206185	206185	206185	206185	206185
LARGE HANDRAIL(PORTIONING SHELF)800 MM	206186	206186	206186	206186	206186	206186
LEFT SIDE DOOR FOR OPEN BASE CUPBOARD				206195	206195	206195
PAIR OF SIDE KICKING STRIPS				206249	206249	206249
PRESSURE REGULATOR FOR GAS UNITS	927225	927225	927225	927225	927225	927225
RIGHT AND LEFT SIDE HANDRAILS	206240	206240	206240	206240	206240	206240
RIGHT SIDE DOOR FOR OPEN BASE CUPBOARD				206194	206194	206194
SCRAPER FOR RIBBED PLATE FRY TOP		164257			164257	
SCRAPER FOR SMOOTH PLATE FRY TOP	164255			164255		
SIDE WALL FOR CUPBOARD				206252	206252	206252
SUPPORT FOR "BRIDGE" SYSTEM 1000 MM	206138	206138	206138			
SUPPORT FOR "BRIDGE" SYSTEM 1200 MM	206139	206139	206139			
SUPPORT FOR "BRIDGE" SYSTEM 1400 MM	206140	206140	206140			
SUPPORT FOR "BRIDGE" SYSTEM 1600 MM	206141	206141	206141			
SUPPORT FOR "BRIDGE" SYSTEM 400 MM	206154	206154	206154			
SUPPORT FOR "BRIDGE" SYSTEM 800 MM	206137	206137	206137			
WATER COLUMN EXTENSION FOR 700 LINE	206291	206291	206291	206291	206291	206291
WATER COLUMN WITH SWIVEL ARM	206289	206289	206289	206289	206289	206289



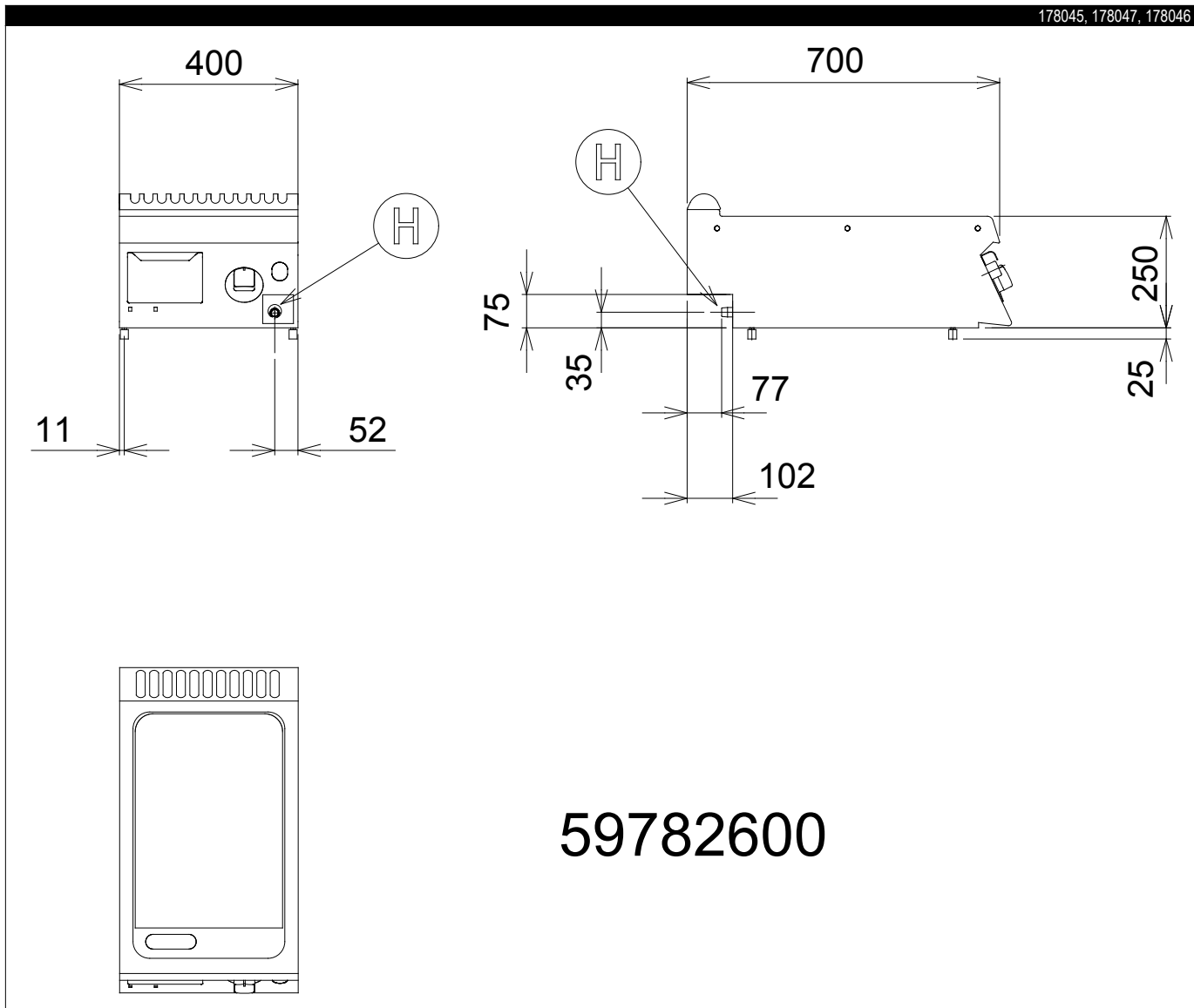

LEGEND			
	KRG400 178045	KRG401 178046	KRG400C 178047
H - Gas connection	1/2"	1/2"	1/2"



www.zanussiprofessional.it

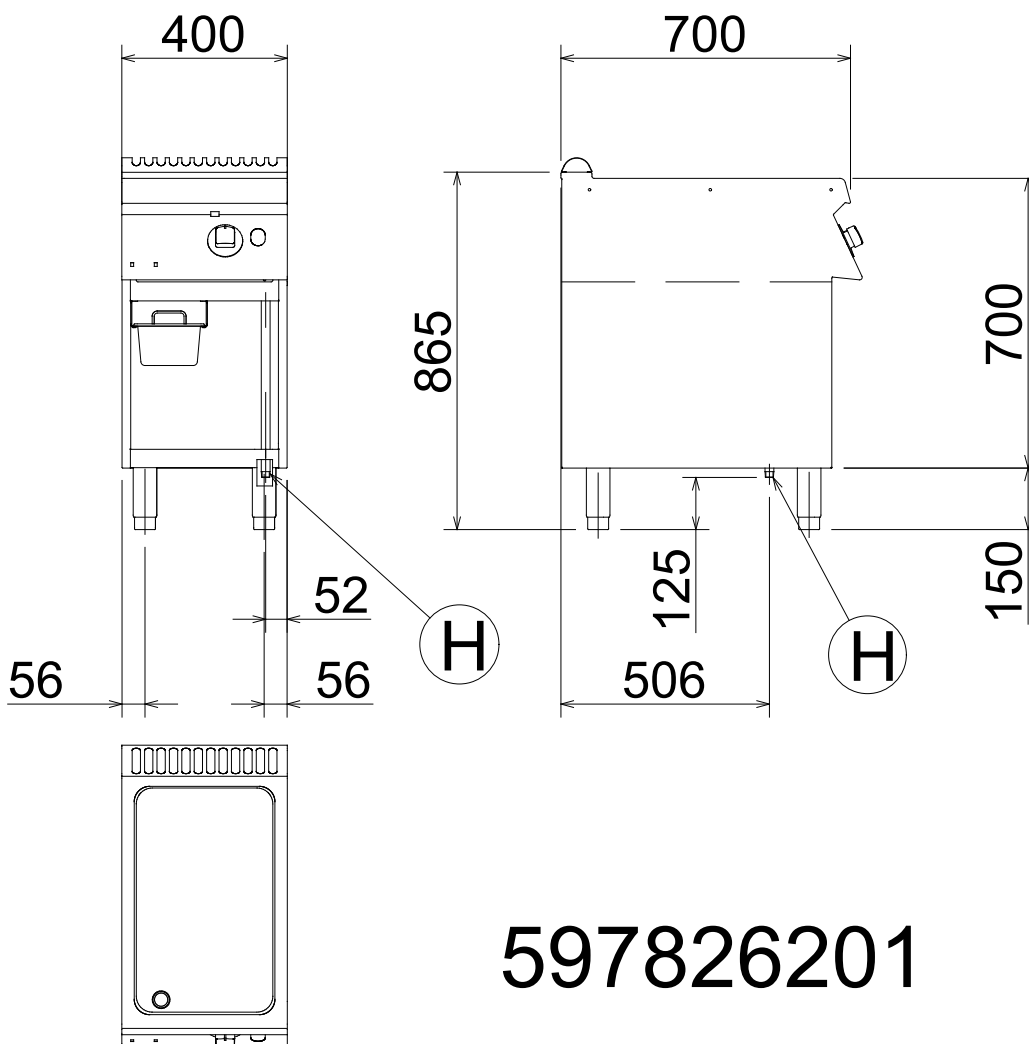

597826201

LEGEND

	KRGV400 178051	KRGV401 178052	KRGV400C 178053
H - Gas connection	1/2"	1/2"	1/2"



www.zanussiprofessional.it