

RANGE COMPOSITION

Ideal for smaller sized catering establishments: bars, pubs, fast food outlets, pizzerias and small hotels; the Snack 600 range of modular cooking appliances consists of a series of appliances each with a depth of 600 mm - in gas and electric - featuring high power for fast service whether in table top situations, where space is a premium, or in a complete cooking installation, using the base units that can include doors, drawers or runners for gastronomic containers.



SCCE 350

SNACK 600

CHIP SCUTTLES **ZANUSSI**
PROFESSIONAL

FUNCTIONAL AND CONSTRUCTION FEATURES

- ◆ Constructed completely in 18/10, 304 AISI stainless steel to guarantee a hard-wearing performance
- ◆ Hygiene guaranteed by rounded edges, flush fit between units, side upstands and sealing joints, completely smooth and easy to clean surfaces and rear splashback
- ◆ Extractable 2/3 GN well with rounded corners
- ◆ Extractable false bottom
- ◆ Adjustable temperature
- ◆ Heating from above the well via infrared lamps
- ◆ The chip scuttle can be mounted on open base cupboards with hinged doors, a chest of drawers or runners for gastronomic containers available as accessories
- ◆ Scoop for chips as optional
- ◆ All models comply with the standards required by the main international approval

bodies and are CE marked.

TECHNICAL DATA	
CHARACTERISTICS	MODELS
	SCCE350 285753
Power supply	Electric
External dimensions - mm	
width	350
depth	600
height	300
Power - kW	
installed-electric	0.6
Usable well dimensions - mm	
width	325
depth	354
Net weight - kg.	12
Supply voltage	230 V, 1N, 50/60

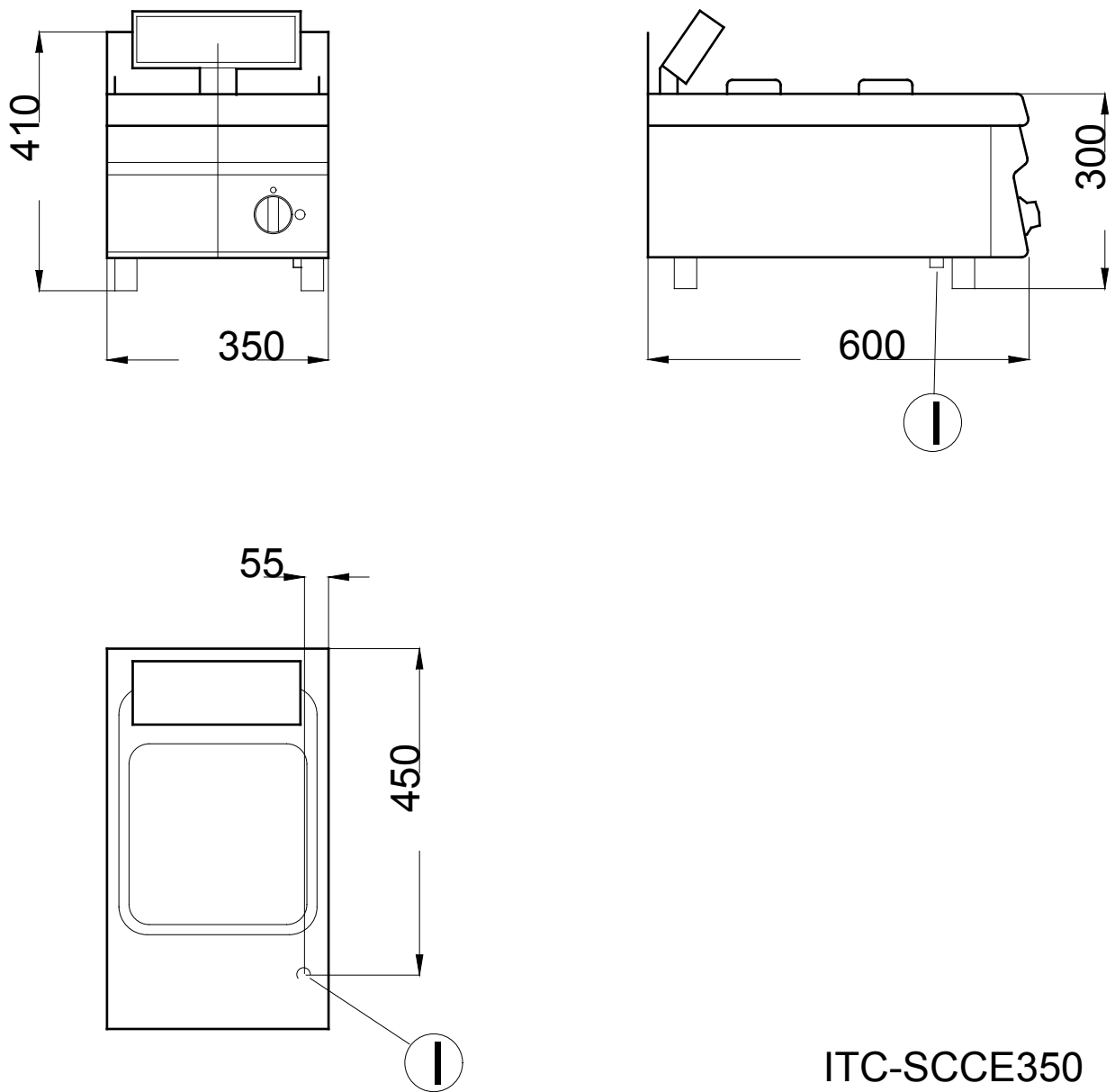

ITC-SCCE350

LEGEND

	SCCE350 285753
I - Electrical connection	230 V, 1N, 50/60



OPTIONAL ACCESSORIES	
ACCESSORIES	MODELS
	SCCE350 285753
GULLEY WITH JOINING PANEL FOR 600 LINE	285798
SCOOP FOR CHIPS	285801



www.zanussiprofessional.it