

RANGE COMPOSITION

N 700: a range of over 100 models for the professional caterer designed to guarantee the highest level of performance, reliability, energy saving, safety standards and ergonomic operation. These concepts are reflected in the total modularity of the range that ensures numerous configurations, either free-standing or bridged. N700 demonstrates how advanced technology can satisfy the needs of the professional caterer.

The models detailed on this sheet are infrared cook tops available in half or full module.



178024

N 700

INFRARED COOK TOPS **ZANUSSI** PROFESSIONAL

FUNCTIONAL AND CONSTRUCTION FEATURES

- ◆ Ceramic glass top, 6 mm thick, lying flush to the stainless steel frame for smooth pan movement and ease of cleaning.
- ◆ The cooking top is sealed to prevent liquid infiltration inside the unit.
- ◆ Heating of the infrared cooking top is via heat radiation produced by ultra high powered electric elements.
- ◆ Radiant elements featuring 2 and 4 concentric heating zones measuring 230 mm in diameter allowing selection of the heating area to match the pot or pan size.
- ◆ Energy regulation of each zone.
- ◆ Warning light to indicate residual heat on the radiant surface for greater operator safety.
- ◆ Front panel in stainless steel with Scotch Brite finish.
- ◆ All models have right-angled side edges to allow flush fitting joints between units.

- ◆ IPX4 water protection.
- ◆ Main connections can be via the rear or the base of the unit.
- ◆ All models can be easily mounted on open base cupboards or bridging supports.
- ◆ All top models provided with service duct to facilitate installation.

TECHNICAL DATA				
CHARACTERISTICS	MODELS			
	KINF400 178023	KINF4002 178031	KINF800 178024	KINF8002 178032
Power supply	Electric	Electric	Electric	Electric
External dimensions - mm				
width	400	400	800	800
depth	700	700	700	700
height	250	250	250	250
Back plate dimensions - mm	Ø 230	Ø 230	Ø 230, Ø 230	Ø 230, Ø 230
Back plates power - kW	2.2	2.2	2.2, 2.2	2.2, 2.2
Front plates dimension - mm	Ø 230	Ø 230	Ø 230, Ø 230	Ø 230, Ø 230
Front plates power - kW	2.2	2.2	2.2, 2.2	2.2, 2.2
Total Power - kW	4.4	4.4	8.8	8.8
Net weight - kg.	15	15	35	35
Supply voltage	400 V, 3N, 50/60	230 V, 3, 50/60	400 V, 3N, 50/60	230 V, 3, 50/60

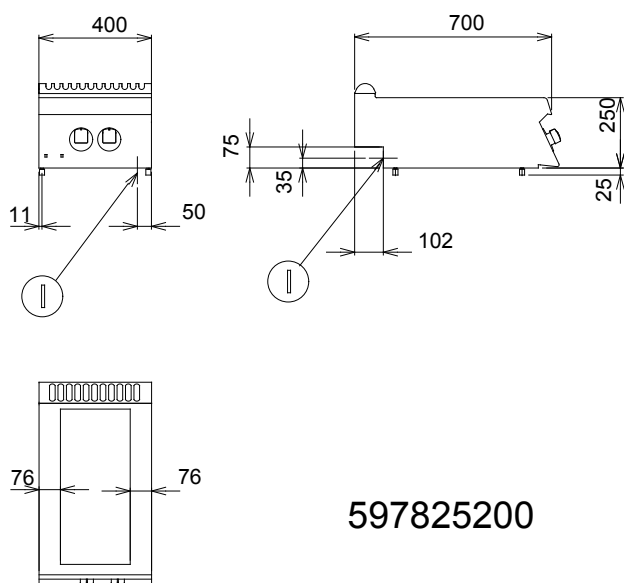

597825200

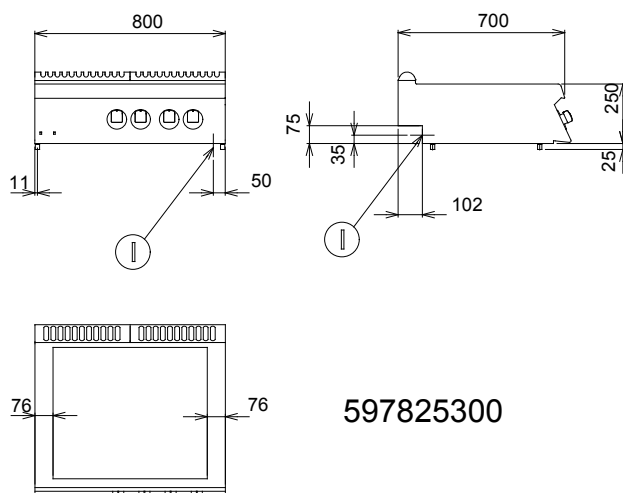

597825300

LEGEND

	KINF400 178023	KINF4002 178031	KINF800 178024	KINF8002 178032
I - Electrical connection	400 V, 3N, 50/60	230 V, 3, 50/60	400 V, 3N, 50/60	230 V, 3, 50/60

OPTIONAL ACCESSORIES

ACCESSORIES	MODELS			
	KINF400 178023	KINF4002 178031	KINF800 178024	KINF8002 178032
2 SIDE COVERING PANELS FOR TOP-D=700MM	206277	206277	206277	206277
CHIMNEY COVER 400MM OPEN	206284	206284		
CHIMNEY COVER 800MM OPEN-LARGE CHIMNEY			206273	206273
FRONTAL HANDRAIL 1200 MM	206191	206191	206191	206191
FRONTAL HANDRAIL 1600 MM	206192	206192	206192	206192
FRONTAL HANDRAIL 400 MM	206166	206166	206166	206166
FRONTAL HANDRAIL 800 MM	206167	206167	206167	206167
LARGE HANDRAIL(PORTIONING SHELF)400 MM	206185	206185	206185	206185
LARGE HANDRAIL(PORTIONING SHELF)800 MM	206186	206186	206186	206186
RIGHT AND LEFT SIDE HANDRAILS	206240	206240	206240	206240
SUPPORT FOR "BRIDGE" SYSTEM 1000 MM	206138	206138	206138	206138
SUPPORT FOR "BRIDGE" SYSTEM 1200 MM	206139	206139	206139	206139
SUPPORT FOR "BRIDGE" SYSTEM 1400 MM	206140	206140	206140	206140
SUPPORT FOR "BRIDGE" SYSTEM 1600 MM	206141	206141	206141	206141
SUPPORT FOR "BRIDGE" SYSTEM 400 MM	206154	206154	206154	206154
SUPPORT FOR "BRIDGE" SYSTEM 800 MM	206137	206137	206137	206137
WATER COLUMN EXTENSION FOR 700 LINE	206291	206291	206291	206291
WATER COLUMN WITH SWIVEL ARM	206289	206289	206289	206289



www.zanussiprofessional.it