

RANGE COMPOSITION

N 700: a range of over 100 models for the professional caterer designed to guarantee the highest level of performance, reliability, energy saving, safety standards and ergonomic operation. These concepts are reflected in the total modularity of the range that ensures numerous configurations, either free-standing or bridged. N 700 demonstrates how advanced technology can satisfy the needs of the professional caterer. The models detailed on this sheet are infrared cooking ranges on open base or on electric oven.



178026

N 700

INFRARED RANGES ZANUSSI PROFESSIONAL

FUNCTIONAL AND CONSTRUCTION FEATURES

- ◆ Ceramic glass top, 6 mm thick, lying flush to the stainless steel frame for smooth pan movement and ease of cleaning.
- ◆ The cooking top is sealed to prevent liquid infiltration inside the unit.
- ◆ Heating of the infrared cooking top is via heat radiation produced by ultra high powered electric elements.
- ◆ Radiant elements featuring 4 concentric circular heating zones measuring 230 mm in diameter allowing selection of the heating area to match the pot or pan size.
- ◆ Energy regulation of each zone.
- ◆ Warning light to indicate residual heat on the radiant surface for greater operator safety.
- ◆ Stainless steel oven chamber with 3 levels of runners to accommodate 2/1GN shelves.
- ◆ Handles on the oven in stainless

steel.

- ◆ Front panel in stainless steel with Scotch Brite finish.
- ◆ Feet in stainless steel adjustable in height 50mm.
- ◆ All models have right-angled side edges to allow flush fitting joins

between units, eliminating gaps and possible dirt traps.

- ◆ IPX4 water protection.
- ◆ Main connections can be via the rear or the base of the unit.

TECHNICAL DATA			
CHARACTERISTICS	MODELS		
	KINFFV800 178026	KINFFE800 178025	KINFFE8002 178033
Power supply	Electric	Electric	Electric
External dimensions - mm			
width	800	800	800
depth	700	700	700
height	850	850	850
Oven cavity - mm			
width		540	540
depth		650	650
height		300	300
Oven			
heat input - kW		6	6
temperature min-max - °C		140, 300	140, 300
Storage cupboard - mm			
width	680		
depth	640		
height	420		
Back plate dimensions - mm	Ø 230, Ø 230	Ø 230, Ø 230	Ø 230, Ø 230
Back plates power - kW	2.2, 2.2	2.2, 2.2	2.2, 2.2
Front plates dimension - mm	Ø 230, Ø 230	Ø 230, Ø 230	Ø 230, Ø 230
Front plates power - kW	2.2, 2.2	2.2, 2.2	2.2, 2.2
Total Power - kW	8.8	14.8	14.8
Net weight - kg.	40	85	85
Supply voltage	400 V, 3N, 50/60	400 V, 3N, 50/60	230 V, 3, 50/60
INCLUDED ACCESSORIES			
2/1 GN CHROME GRID		1	1

178026

178025, 178033

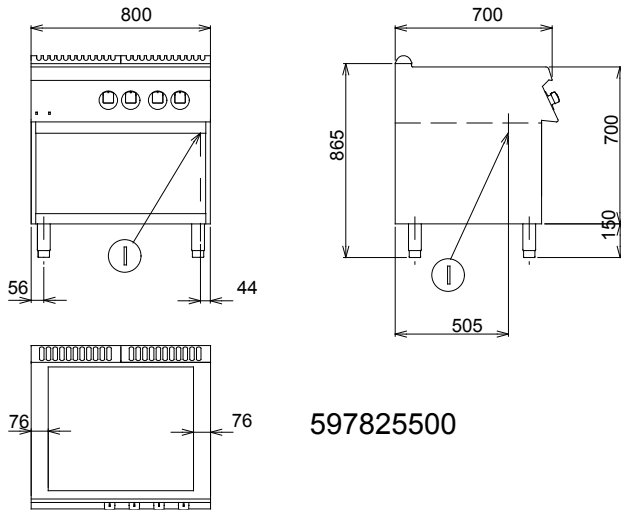

597825500

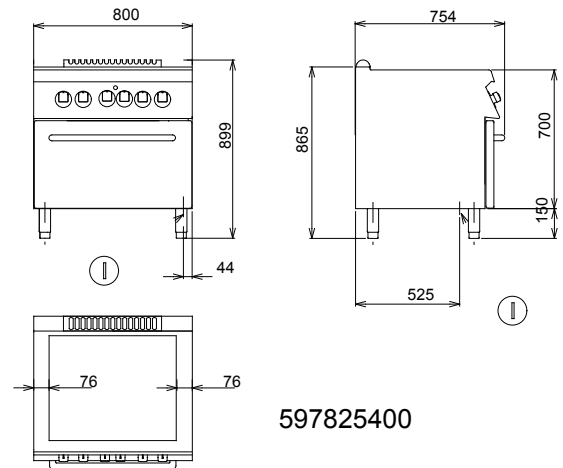

597825400

LEGEND

	KINFFV800 178026	KINFFE800 178025	KINFFE8002 178033
I - Electrical connection	400 V, 3N, 50/60	400 V, 3N, 50/60	230 V, 3, 50/60

OPTIONAL ACCESSORIES

ACCESSORIES	MODELS		
	KINFFV800 178026	KINFFE800 178025	KINFFE8002 178033
2 DRAWERS FOR OPEN BASE	206255		
2 SIDE COVERING PANELS FOR TOP-D=700MM	206277	206277	
2 SIDE COVERING PANELS H=700 D=700	206000	206000	206000
2 SIDE KICKING STRIPS-CONCRETE INSTALL.	206265	206265	206265
2 SUPPORTS+RUNNERS FOR 4 GN 1/1&2/1 CONT	206244		
2/1 GN CHROME GRID		164250	164250
4 FEET FOR CONCRETE INSTALLATION	206210	206210	206210
4 WHEELS (2 WITH BRAKE)	206188	206188	206188
CENTRAL SUPPORT FOR 800MM/1200MM CUPB.	206245		
CHIMNEY COVER 800MM OPEN-LARGE CHIMNEY	206273		
CHIMNEY COVER 800MM OPEN-SMALL CHIMNEY		206272	206272
ELECTRIC HEATING KIT FOR CUPBOARDS	206259		
FLANGED FEET KIT	206136	206136	206136
FRONT.KICK.STRIP F.CONCRETE INST.1000 MM	206150	206150	206150
FRONT.KICK.STRIP F.CONCRETE INST.1200 MM	206151	206151	206151
FRONT.KICK.STRIP F.CONCRETE INST.1600 MM	206152	206152	206152
FRONT.KICK.STRIP F.CONCRETE INST.200 MM	206146	206146	206146
FRONT.KICK.STRIP F.CONCRETE INST.400 MM	206147	206147	206147
FRONT.KICK.STRIP F.CONCRETE INST.800 MM	206148	206148	206148
FRONTAL HANDRAIL 1200 MM	206191	206191	206191
FRONTAL HANDRAIL 1600 MM	206192	206192	206192
FRONTAL HANDRAIL 400 MM	206166	206166	206166
FRONTAL HANDRAIL 800 MM	206167	206167	206167
FRONTAL KICKING STRIP 1000 MM	206177	206177	206177
FRONTAL KICKING STRIP 1200 MM	206178	206178	206178
FRONTAL KICKING STRIP 1600 MM	206179	206179	206179
FRONTAL KICKING STRIP 200 MM	206174	206174	206174
FRONTAL KICKING STRIP 400 MM	206175	206175	206175
FRONTAL KICKING STRIP 800 MM	206176	206176	206176
LARGE HANDRAIL(PORTIONING SHELF)400 MM	206185	206185	206185
LARGE HANDRAIL(PORTIONING SHELF)800 MM	206186	206186	206186
LEFT SIDE DOOR FOR OPEN BASE CUPBOARD	206195		
PAIR OF SIDE KICKING STRIPS	206249	206249	206249
RIGHT AND LEFT SIDE HANDRAILS	206240	206240	206240
RIGHT SIDE DOOR FOR OPEN BASE CUPBOARD	206194		
SIDE WALL FOR CUPBOARD	206252		
WATER COLUMN EXTENSION FOR 700 LINE	206291	206291	206291
WATER COLUMN WITH SWIVEL ARM	206289	206289	206289



www.zanussiprofessional.it