

RANGE COMPOSITION

Ideal for smaller sized catering establishments: bars, pubs, fast food outlets, pizzerias and small hotels; the Snack 600 range of modular cooking appliances consists of a series of appliances each with a depth of 600 mm - in gas and electric - featuring high power for fast service whether in table top situations, where space is at a premium, or in a complete cooking installation, using the base units that can include doors, drawers or runners for gastrorm containers.



SNACK 600

FRYERS TOPS **ZANUSSI**
PROFESSIONAL

FUNCTIONAL AND CONSTRUCTION FEATURES

- ◆ Constructed completely in 18/10, 304 AISI stainless steel to guarantee a hard-wearing performance.
- ◆ Hygiene guaranteed by rounded edges, flush fit between units, side upstands and sealing joints, completely smooth and easy to clean surfaces and rear splashback.
- ◆ Thermostatically controlled temperature for each well.
- ◆ Temperature adjustable from 90° to 190°C on electric models and 90° to 185°C on gas models.
- ◆ High limit safety thermostat.
- ◆ Tilting elements with safety stop for ease of cleaning (electric models)
- ◆ On/Off switch for electric models
- ◆ Oil drainage via a tap and extendable hose positioned on the front of the unit.
- ◆ Heating via incoloy armoured steel elements on electric model
- ◆ Pressed well in 304 AISI stainless steel with expansion zone and equipped with a basket 210 x 260 x 105 mm in size
- ◆ Gas models are equipped with high-power burners with flame tubes immersed in the oil, automatic piezo ignition, flame failure device and pilot light
- ◆ All gas appliances are supplied for use

with natural gas, with LPG conversion jets supplied as standard

- ◆ The fryers can be mounted on open base cupboards with hinged doors, a chest of drawers or runners for gastrorm containers available as accessories
- ◆ All models comply with the standards required by the main international approval bodies and are CE marked.

TECHNICAL DATA				
CHARACTERISTICS	MODELS			
	SFRE350 285751	SFRE700 285752	SFRG350 285762	SFRG700 285763
Power supply	Electric	Electric	Gas	Gas
Capacity lt.	8	2x8	7	2x7
External dimensions - mm				
width	350	700	350	700
depth	600	600	600	600
height	300	300	300	300
Power - kW				
gas			6.25	12.5
installed-electric	6	12		
Net weight - kg.	14	27	19	37
Supply voltage	400 V, 3N, 50/60	400 V, 3N, 50/60		
INCLUDED ACCESSORIES				
BASKET FOR FRYER	1	2	1	2

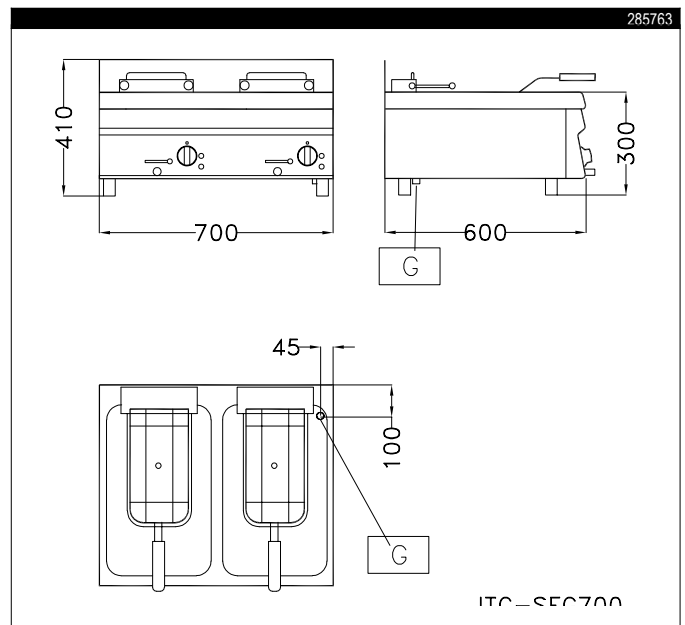
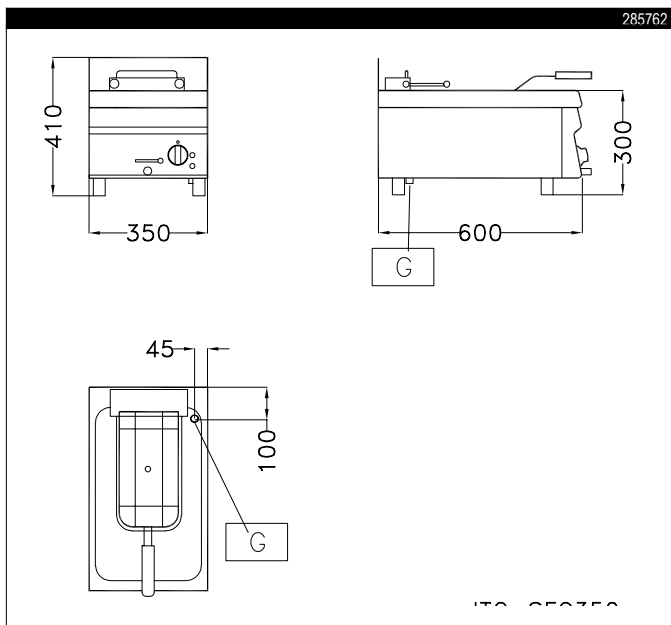
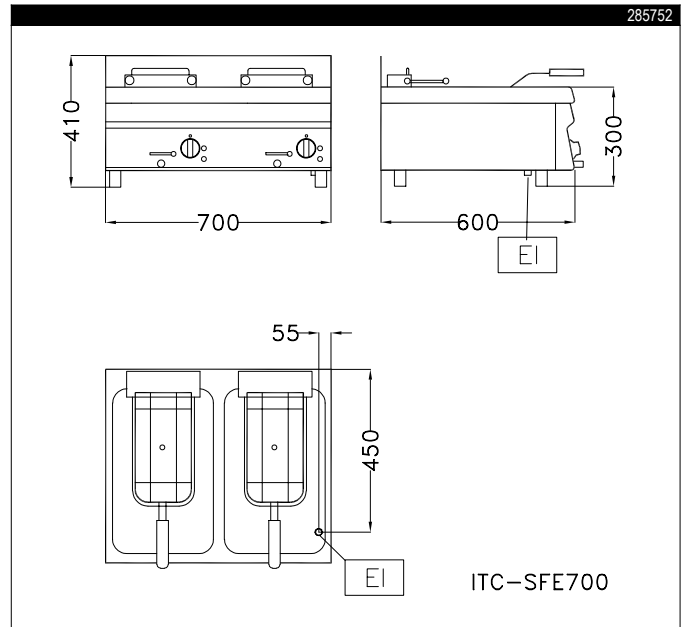
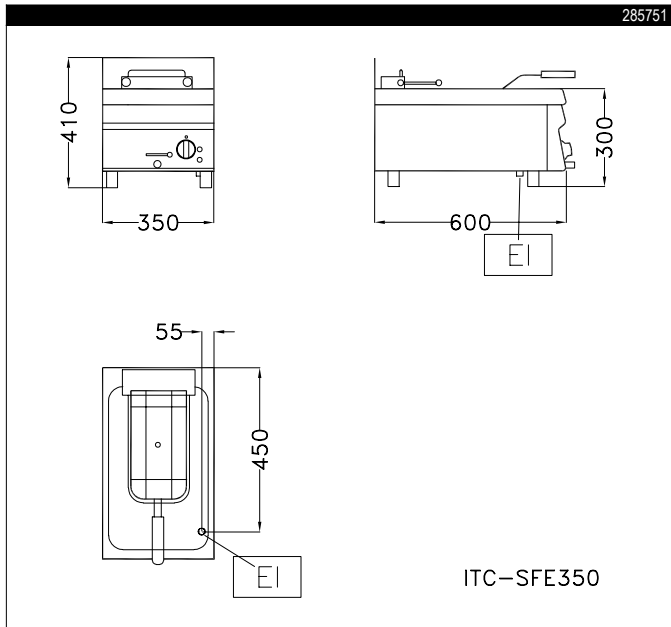

LEGEND	SFRE350 285751	SFRE700 285752	SFRG350 285762	SFRG700 285763
EI - Electrical connection	400 V, 3N, 50/60	400 V, 3N, 50/60		
G - Gas connection			1/2"	1/2"



OPTIONAL ACCESSORIES	MODELS			
ACCESSORIES	SFRE350 285751	SFRE700 285752	SFRG350 285762	SFRG700 285763
BASKET FOR FRYER	285795	285795	285795	285795
GULLEY WITH JOINING PANEL FOR 600 LINE	285798	285798	285798	285798



www.zanussiprofessional.com