

RANGE COMPOSITION

N 700: a range of over 100 models for the professional caterer designed to guarantee the highest level of performance, reliability, energy saving, safety standards and ergonomic operation. These concepts are reflected in the total modularity of the range that ensures numerous configurations, either free-standing or bridged. N 700 demonstrates how advanced technology can satisfy the needs of the professional caterer.

The models detailed on this sheet are 14 litres electric fryers with one or two wells.



178124

N 700

ELECTRIC FRYERS - 14 LT ZANUSSI PROFESSIONAL

FUNCTIONAL AND CONSTRUCTION FEATURES

- ◆ Incoloy armoured high efficiency heating elements.
- ◆ Working temperature from 105°C to 185°C.
- ◆ Additional overheat safety thermostat.
- ◆ Heating elements inside the well.
- ◆ All models have right-angled side edges to allow flush-fitting joins between units, eliminating gaps and possible dirt traps.
- ◆ Worktop in 1,5mm stainless steel. Front panel in stainless steel with Scotch Brite finish.
- ◆ Feet in stainless steel adjustable in height 50mm.
- ◆ Door with handles in stainless steel.
- ◆ Oil drainage via a tap into a drainage container positioned under the well thus simplifying the consumed oil management and guaranteeing the operator safety.
- ◆ Main connections can be via the

rear or the base of the unit.

TECHNICAL DATA			
CHARACTERISTICS	MODELS		
	KFRE460 178124	KFRE810 178125	KFRE8102 178133
Power supply	Electric	Electric	Electric
External dimensions - mm			
width	400	800	800
depth	700	700	700
height	850	850	850
height adjustment	50	50	50
N° of wells	1	2	2
Usable well dimensions - mm			
width	240	240	240
depth	380	380	380
height	285	285	285
Thermostatic	●	●	●
Temperature limiter	●	●	●
Well capacity - min/max - lt.	12, 14	12, 14	12, 14
Power - kW			
installed-electric	8.7	17.4	17.4
Net weight - kg.	35	81	81
Supply voltage	400 V, 3N, 50/60	400 V, 3N, 50/60	230 V, 3, 50/60
INCLUDED ACCESSORIES			
BASKET FOR 14/15 LT FRYERS	1	2	2
LEFT SIDE DOOR FOR OPEN BASE CUPBOARD		1	1
RIGHT SIDE DOOR FOR OPEN BASE CUPBOARD	1	1	1

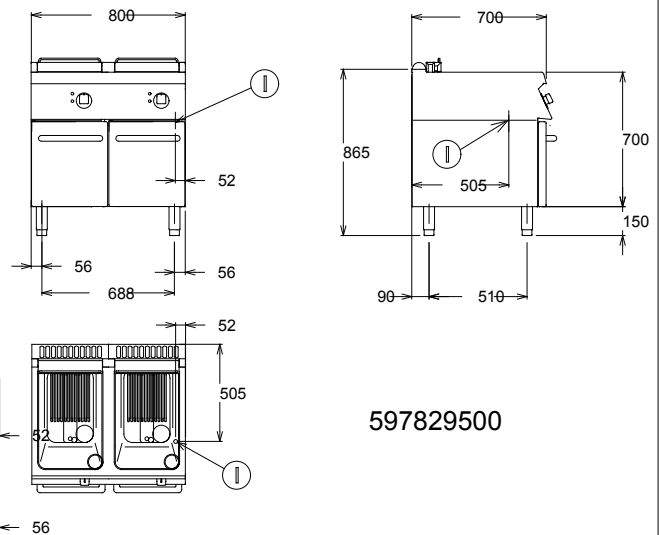
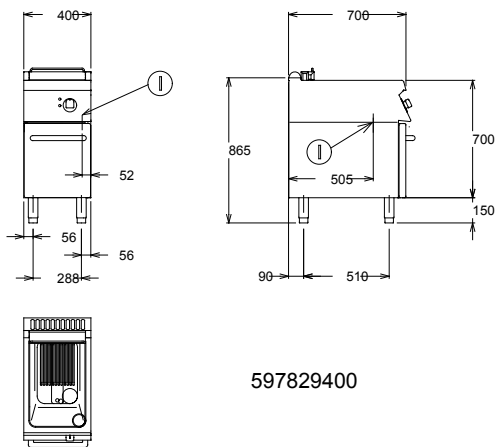

LEGEND

	KFRE460 178124	KFRE810 178125	KFRE8102 178133
I - Electrical connection	400 V, 3N, 50/60	400 V, 3N, 50/60	230 V, 3, 50/60

OPTIONAL ACCESSORIES

ACCESSORIES	MODELS		
	KFRE460 178124	KFRE810 178125	KFRE8102 178133
2 1/2 BASKETS FOR 14/15 LT FRYERS	921692	921692	921692
2 SIDE COVERING PANELS FOR TOP-D=700MM	206277	206277	
2 SIDE COVERING PANELS H=700 D=700	206000	206000	206000
2 SIDE KICKING STRIPS-CONCRETE INSTALL.	206265	206265	206265
4 FEET FOR CONCRETE INSTALLATION	206210	206210	206210
BASKET FOR 14/15 LT FRYERS	921691	921691	921691
FILTER FOR FRYER OIL COLLECTION BASIN	921693	921693	921693
FLANGED FEET KIT	206136	206136	206136
FRONT.KICK.STRIP F.CONCRETE INST.1000 MM	206150	206150	206150
FRONT.KICK.STRIP F.CONCRETE INST.1200 MM	206151	206151	206151
FRONT.KICK.STRIP F.CONCRETE INST.1600 MM	206152	206152	206152
FRONT.KICK.STRIP F.CONCRETE INST.200 MM	206146	206146	206146
FRONT.KICK.STRIP F.CONCRETE INST.400 MM	206147	206147	206147
FRONT.KICK.STRIP F.CONCRETE INST.800 MM	206148	206148	206148
FRONTAL HANDRAIL 1200 MM	206191	206191	206191
FRONTAL HANDRAIL 1600 MM	206192	206192	206192
FRONTAL HANDRAIL 400 MM	206166	206166	206166
FRONTAL HANDRAIL 800 MM	206167	206167	206167
FRONTAL KICKING STRIP 1000 MM	206177	206177	206177
FRONTAL KICKING STRIP 1200 MM	206178	206178	206178
FRONTAL KICKING STRIP 1600 MM	206179	206179	206179
FRONTAL KICKING STRIP 200 MM	206174	206174	206174
FRONTAL KICKING STRIP 400 MM	206175	206175	206175
FRONTAL KICKING STRIP 800 MM	206176	206176	206176
LARGE HANDRAIL(PORTIONING SHELF)400 MM	206185	206185	206185
LARGE HANDRAIL(PORTIONING SHELF)800 MM	206186	206186	206186
LEFT SIDE DOOR FOR OPEN BASE CUPBOARD	206195		
PAIR OF SIDE KICKING STRIPS	206249	206249	206249
RIGHT AND LEFT SIDE HANDRAILS	206240	206240	206240



www.zanussiprofessional.it