

RANGE COMPOSITION

N 700: a range of over 100 models for the professional caterer designed to guarantee the highest level of performance, reliability, energy saving, safety standards and ergonomic operation. These concepts are reflected in the total modularity of the range that ensures numerous configurations, either free-standing or bridged. N 700 demonstrates how advanced technology can satisfy the needs of the professional caterer. The models detailed in this sheet are electric fry tops in full module version with smooth, ribbed or smooth/ribbed plates in mild steel or chromium-plated steel.



178070

N 700

FULL MODULE ELECTRIC FRY TOPS **ZANUSSI** PROFESSIONAL

FUNCTIONAL AND CONSTRUCTION FEATURES

◆ Elements in incoloy positioned under the cooking plate.

◆ Safety thermostat and thermostatic control (temperature markings in °C).
◆ Worktop in 1,5mm stainless steel. Front panel in stainless steel with Scotch Brite finish.

TECHNICAL DATA									
CHARACTERISTICS	MODELS								
	KRE800 178062	KRE8002 178075	KRE813 178063	KRE800C 178064	KRE813C 178071	KRE813C2 178076	KREV800 178068	KREV813 178069	KREV800C 178070
Power supply	Electric	Electric	Electric	Electric	Electric	Electric	Electric	Electric	Electric
External dimensions - mm									
width	800	800	800	800	800	800	800	800	800
depth	700	700	700	700	700	700	700	700	700
height	250	250	250	250	250	250	850	850	850
Cooking surface material	Mild Steel	Mild Steel	Mild Steel	Chromium Plated	Chromium Plated	Chromium Plated	Mild Steel	Mild Steel	Chromium Plated
Thermostatic	●	●	●	●	●	●	●	●	●
Cooking surface dimensions - mm									
width	730	730	730	730	730	730	730	730	730
depth	540	540	540	540	540	540	540	540	540
Working temperature - min/max - °C	110, 300	110, 300	110, 300	110, 300	110, 300	110, 300	110, 300	110, 300	110, 300
Storage cupboard - mm									
width							680	680	680
depth							640	640	640
height							420	420	420
Electrical power - kW	9	9	9	9	9	9	9	9	9
Net weight - kg.	70	70	70	70	70	70	80	80	80
Supply voltage	400 V, 3N, 50/60	230 V, 3, 50/60	400 V, 3N, 50/60	400 V, 3N, 50/60	400 V, 3N, 50/60	230 V, 3, 50/60	400 V, 3N, 50/60	400 V, 3N, 50/60	400 V, 3N, 50/60
Smooth cooking surface	●	●	●	●	●	●	●	●	●
Smooth/Ribbed cooking surface			●		●	●		●	
INCLUDED ACCESSORIES									
SCRAPER FOR RIBBED PLATE FRY TOP					1	1			
SCRAPER FOR SMOOTH PLATE FRY TOP				1	1	1			1

- ◆ All models have right-angled side edges to allow flush fitting joints between units.
- ◆ Very quick heat-up time to maximum temperature.
- ◆ Units have separate controls for each 1/2 module of the cooking surface.
- ◆ Cooking surface in mild steel: available smooth, ribbed or smooth/ribbed for optimum grilling results.
- ◆ The standard Fry Top cooking plate is manufactured from 15mm thick special mild steel for even temperature distribution. Ideal

- for grilling, browning and the radiant heat allows thicker cuts of meat to be cooked perfectly.
- ◆ The chromium surface means no absorption of cooking juices into the plate resulting in higher output of product and more flexibility. Very little energy is lost to the kitchen environment due to the reflective qualities of the chromium surface, making the work area more comfortable.
 - ◆ On the cooking surface there is a large drain hole to drain fat into a 2-lt grease

- collection drawer (for top models) or into a 3,5-lt grease collection tray, extractable from open base (for models on base).
- ◆ Splashback in stainless steel included as standard.
 - ◆ IPX4 water protection.
 - ◆ Main connections can be via the rear of the base of the unit.
 - ◆ All top models can be easily mounted on open base cupboards or bridging supports.
 - ◆ All top models provided with service duct to facilitate installation.

OPTIONAL ACCESSORIES ACCESSORIES	MODELS								
	KRE800 178062	KRE800C 178075	KRE813 178063	KRE800C 178064	KRE813C 178071	KRE813C2 178076	KREV800 178068	KREV813 178069	KREV800C 178070
2 DRAWERS FOR OPEN BASE							206255	206255	
2 INTERNAL SIDE PANELS FOR HYGIENIC CUPB							206252	206252	206252
2 SIDE COVERING PANELS FOR TOP-D=700MM	206277	206277	206277	206277	206277	206277	206277	206277	206277
2 SIDE COVERING PANELS H=700 D=700							206000	206000	206000
2 SIDE KICKING STRIPS-CONCRETE INSTALL.							206265	206265	206265
2 SUPPORTS+RUNNERS FOR 4 GN 1/1&2/1 CONT							206244	206244	206244
4 FEET FOR CONCRETE INSTALLATION							206210	206210	206210
4 WHEELS (2 WITH BRAKE)							206188	206188	206188
CENTRAL SUPPORT FOR 800MM/1200MM CUPB.							206245	206245	
CHIMNEY COVER 800MM OPEN-LARGE CHIMNEY	206273	206273	206273	206273	206273	206273	206273	206273	206273
CHIMNEY UPSTAND 800MM	206304	206304	206304	206304	206304	206304	206304	206304	206304
ELECTRIC HEATING KIT FOR CUPBOARDS							206259	206259	206259
FLANGED FEET KIT							206136	206136	206136
FRONT.KICK.STRIP F.CONCRETE INST.1000 MM							206150	206150	206150
FRONT.KICK.STRIP F.CONCRETE INST.1200 MM							206151	206151	206151
FRONT.KICK.STRIP F.CONCRETE INST.1600 MM							206152	206152	206152
FRONT.KICK.STRIP F.CONCRETE INST.200 MM							206146	206146	206146
FRONT.KICK.STRIP F.CONCRETE INST.400 MM							206147	206147	206147
FRONT.KICK.STRIP F.CONCRETE INST.800 MM							206148	206148	206148
FRONTAL HANDRAIL 1200 MM	206191	206191	206191	206191	206191	206191	206191	206191	206191
FRONTAL HANDRAIL 1600 MM	206192	206192	206192	206192	206192	206192	206192	206192	206192
FRONTAL HANDRAIL 400 MM	206166	206166	206166	206166	206166	206166	206166	206166	206166
FRONTAL HANDRAIL 800 MM	206167	206167	206167	206167	206167	206167	206167	206167	206167
FRONTAL KICKING STRIP 1000 MM							206177	206177	206177
FRONTAL KICKING STRIP 1200 MM							206178	206178	206178
FRONTAL KICKING STRIP 1600 MM							206179	206179	206179
FRONTAL KICKING STRIP 200 MM							206174	206174	206174
FRONTAL KICKING STRIP 400 MM							206175	206175	206175
FRONTAL KICKING STRIP 800 MM							206176	206176	206176
LARGE HANDRAIL(PORTIONING SHELF)400 MM	206185	206185	206185	206185	206185	206185	206185	206185	206185
LARGE HANDRAIL(PORTIONING SHELF)800 MM	206186	206186	206186	206186	206186	206186	206186	206186	206186
LEFT SIDE DOOR FOR OPEN BASE CUPBOARD							206195	206195	206195
PAIR OF SIDE KICKING STRIPS							206249	206249	206249
RIGHT AND LEFT SIDE HANDRAILS	206240	206240	206240	206240	206240	206240	206240	206240	206240
RIGHT SIDE DOOR FOR OPEN BASE CUPBOARD							206194	206194	206194
SCRAPER FOR RIBBED PLATE FRY TOP			164257					164257	
SCRAPER FOR SMOOTH PLATE FRY TOP	164255	164255	164255				164255	164255	
SUPPORT FOR "BRIDGE" SYSTEM 1000 MM	206138	206138	206138	206138	206138	206138			
SUPPORT FOR "BRIDGE" SYSTEM 1200 MM	206139	206139	206139	206139	206139	206139			
SUPPORT FOR "BRIDGE" SYSTEM 1400 MM	206140	206140	206140	206140	206140	206140			
SUPPORT FOR "BRIDGE" SYSTEM 1600 MM	206141	206141	206141	206141	206141	206141			
SUPPORT FOR "BRIDGE" SYSTEM 400 MM	206154	206154	206154	206154	206154	206154			
SUPPORT FOR "BRIDGE" SYSTEM 800 MM	206137	206137	206137	206137	206137	206137			
WATER COLUMN EXTENSION FOR 700 LINE	206291	206291	206291	206291	206291	206291	206291	206291	206291
WATER COLUMN WITH SWIVEL ARM	206289	206289	206289	206289	206289	206289	206289	206289	206289



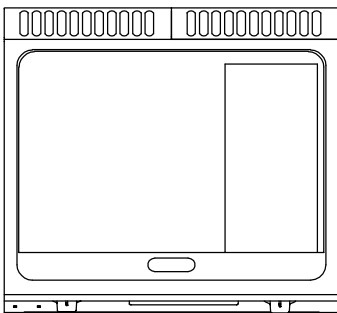
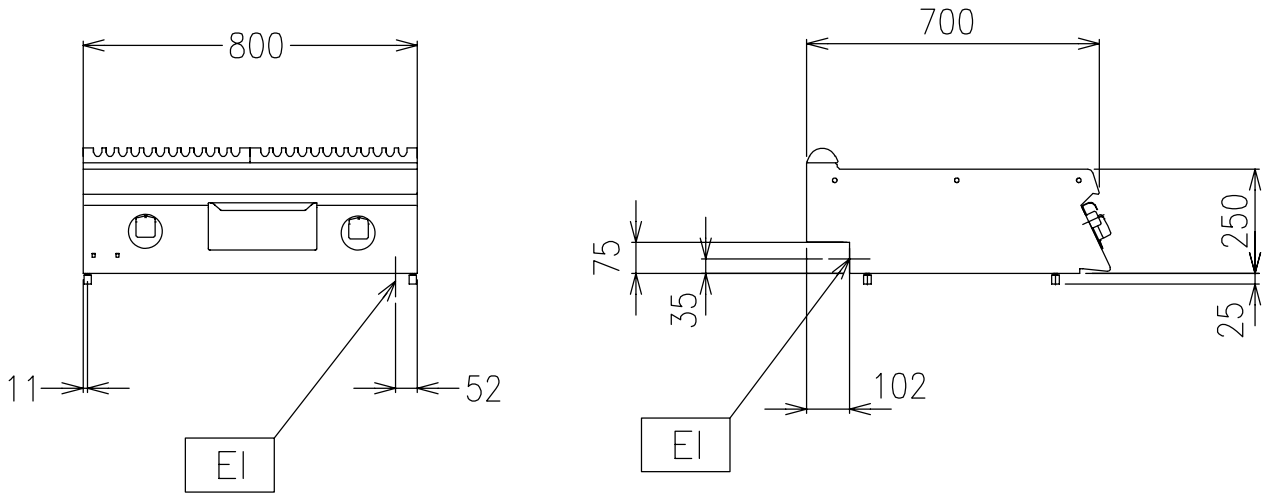

597825700

LEGEND

	KRE800 178062	KRE8002 178075	KRE813 178063	KRE800C 178064	KRE813C 178071	KRE813C2 178076
EI - Electrical connection	400 V, 3N, 50/60	230 V, 3, 50/60	400 V, 3N, 50/60	400 V, 3N, 50/60	400 V, 3N, 50/60	230 V, 3, 50/60



www.zanussiprofessional.com

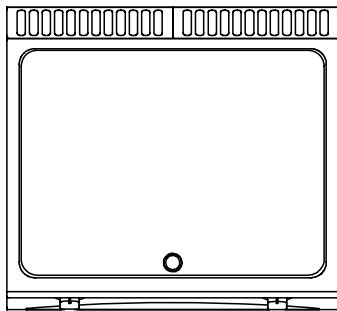
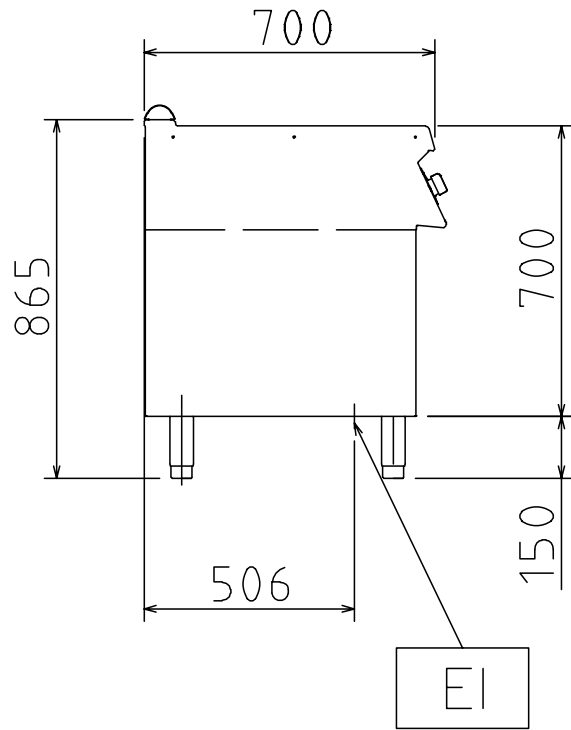
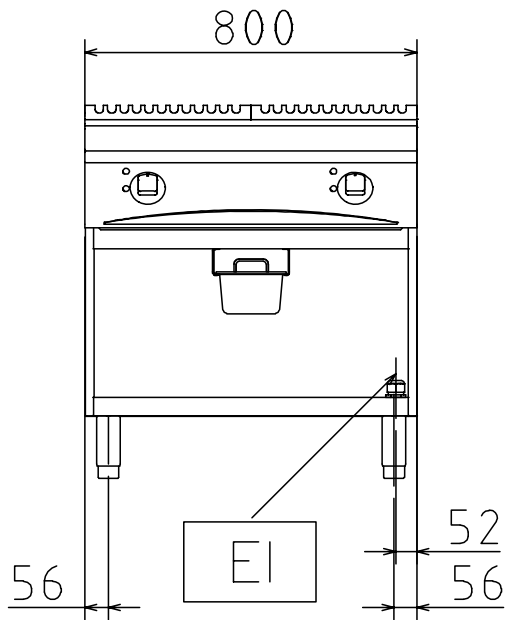

597825901

LEGEND

	KREV800 178068	KREV813 178069	KREV800C 178070
EI - Electrical connection	400 V, 3N, 50/60	400 V, 3N, 50/60	400 V, 3N, 50/60



www.zanussiprofessional.com