

Heavy duty flatwork ironer

C-Flex 900, 1200



Features and benefits

- Chest type industrial ironer with mobile chest and fixed roll, offering a constant pressure and a maximum ironing surface for the utmost ironing quality
- Steam or thermal fluid heating
- The unique design of the chest and roll combined with an improved thermal insulation give a thermal output close to 97%
- Up to three chest can be mounted together for a 50m/min maximum ironing speed
- Simple and reliable drive, possible thanks to the fixed roll technology
- One adjustable suction fan per roll for an improved vapor suction
- Maxpress[®] fitting for an optimum roll and chest contact and an optimized vapor extraction

Main options

- Stainless steel Maxpress[®] fitting for an extended longevity
- Nomex padding withstand temperatures above 180°C
- Extra insulation of the casings for a lower energy consumption and an improved working environment
- Vacuum feeding table for an easier use
- Preset ironing speeds or special speed ranges to customize the ironing to the user specificities
- Connection with feeding and folding systems

Main specifications				C-Flex 900	C-Flex 1200
Max. water evaporation*		l/h		205-795	210-1260
Cylinder	number			1-3	1-3
	diameter	mm		900	1200
	length	mm		2700, 3000, 3300, 3500	2100, 3000, 3300, 3500, 4200
Ironing speed**		m/min		4-51	6-51
Heating	steam consumption***	kg/h		240-960	295-1530

* 12 bars steam heating, smallest – biggest machine and 100% cylinder use, see detailed data

** See detailed data for available speed ranges per dimension

*** 12 bar steam heating, smallest – biggest machine, see detailed data

Electrical connections		927	930	933	935
Voltage					
400-415V 3AC 50Hz – 1 roll	kW		4.6		
400-415V 3AC 50Hz – 2 rolls	kW		12		
400-415V 3AC 50Hz – 3 rolls	kW		22		
Steam and air connections					
Max. steam pressure	kPa		1400		
Compressed air	DN		15		
1 roll					
Steam	DN		32		
Condensate	DN		25		
Exhaust dia. (K)	mm		200		
Evacuated air	m ³ /h		2000		
2 rolls					
Steam	DN		40		
Condensate	DN		32		
Exhaust dia. (K)	mm		2 x 200		
Evacuated air	m ³ /h		2 x 2000		
3 rolls					
Steam	DN		50		
Condensate	DN		40		
Exhaust dia. (K)	mm		3 x 200		
Evacuated air	m ³ /h		3 x 2000		
Sound level					
Airborne sound level	dB(A)		66		
Heat emission					
% of installed power, standard insulation			5		
% of installed power, extra insulation			3		
Performances and energy consumption					
1 roll					
Max. water evaporation (14 bar)	l/h	205	225	250	265
Steam average consumption (12 bar)	kg/h	240	270	300	320
Average linen output (12 bar)*	kg/h	330	370	410	435
Ironing speed**	m/min	5-15			
2 rolls					
Max. water evaporation (14 bar)	l/h	410	450	500	530
Steam average consumption (12 bar)	kg/h	480	540	600	640
Average linen output (12 bar)*	kg/h	660	740	820	870
Ironing speed**	m/min	9-27			
3 rolls					
Max. water evaporation (14 bar)	l/h	615	675	750	795
Steam average consumption (12 bar)	kg/h	720	810	900	960
Average linen output (12 bar)*	kg/h	940	1110	1230	1305
Ironing speed**	m/min	14-42			
Dimensions					
A width	mm	3900	4200	4500	4700
B ironing width	mm	2700	3000	3300	3500
C length 1 roll	mm	1685			
C length 2 rolls	mm	2955			
C length 3 rolls	mm	4225			
D height	mm	1560			
Net weight					
1 roll	kg	3010	3200	3400	3530
2 rolls	kg	5980	6360	6760	7030
3 rolls	kg	8950	9550	10170	10600

* 50% residual moisture, 140 gr/m² polyester-cotton linen, 100% cylinder use

** Other speed range available on request

Electrical connections		1221	1230	1233	1235	1242
Voltage						
	400-415V 3AC 50Hz – 1 roll kW			7.9		
	400-415V 3AC 50Hz – 2 rolls kW			19.6		
	400-415V 3AC 50Hz – 3 rolls kW			30		
Steam and air connections						
Max. steam pressure	kPa			1400		
Compressed air	DN			15		
1 roll						
Steam	DN			40		
Condensate	DN			32		
Exhaust dia. (K)	mm			200		
Evacuated air	m ³ /h			2000		
2 rolls						
Steam	DN			50		
Condensate	DN			40		
Exhaust dia. (K)	mm			2 x 200		
Evacuated air	m ³ /h			2 x 2000		
3 rolls						
Steam	DN			65		
Condensate	DN			50		
Exhaust dia. (K)	mm			3 x 200		
Evacuated air	m ³ /h			3 x 2000		
Sound level						
Airborne sound level	dB(A)			66		
Heat emission						
% of installed power, standard insulation				5		
% of installed power, extra insulation				3		
Performances and energy consumption						
1 roll						
Max. water evaporation (14 bar)	l/h	210	300	330	350	420
Steam average consumption (12 bar)	kg/h	295	360	395	420	510
Average linen output (12 bar)*	kg/h	355	500	550	585	710
Ironing speed**	m/min			8-24		
2 rolls						
Max. water evaporation (14 bar)	l/h	420	600	660	700	840
Steam average consumption (12 bar)	kg/h	590	720	790	840	1020
Average linen output (12 bar)*	kg/h	710	1000	1100	1170	1420
Ironing speed**	m/min			14-43		
3 rolls						
Max. water evaporation (14 bar)	l/h	630	900	990	1050	1260
Steam average consumption (12 bar)	kg/h	885	1080	1185	1260	1530
Average linen output (12 bar)*	kg/h	1065	1500	1650	1755	2130
Ironing speed**	m/min			14-43		
Dimensions						
A width	mm	3300	4200	4500	4700	5400
B ironing width	mm	2100	3000	3300	3500	4200
C length 1 roll	mm			1985		
C length 2 rolls	mm			3555		
C length 3 rolls	mm			5125		
D height	mm			1760		
Net weight						
1 roll	kg	3140	3860	4100	4360	4820
2 rolls	kg	6860	7700	8200	8530	9700
3 rolls	kg	9400	11630	12400	12900	14650

* 50% residual moisture, 140 gr/m² polyester-cotton linen, 100% cylinder use
 ** Other speed range available on request

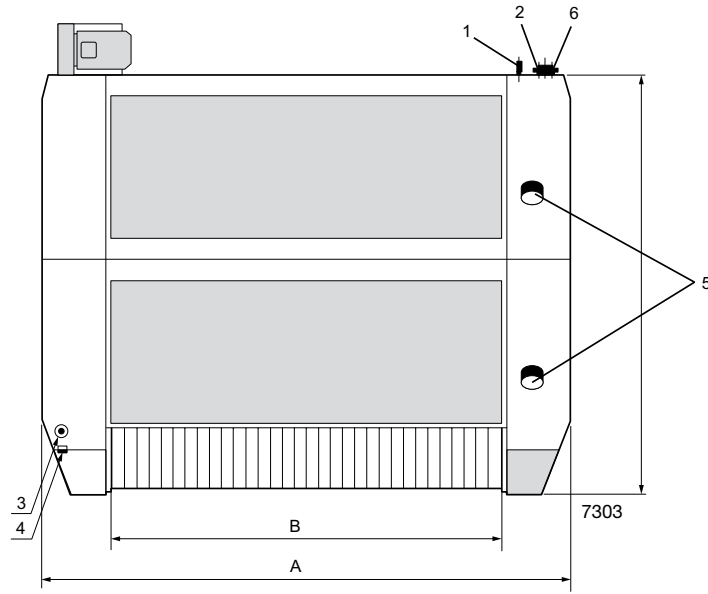

Top view

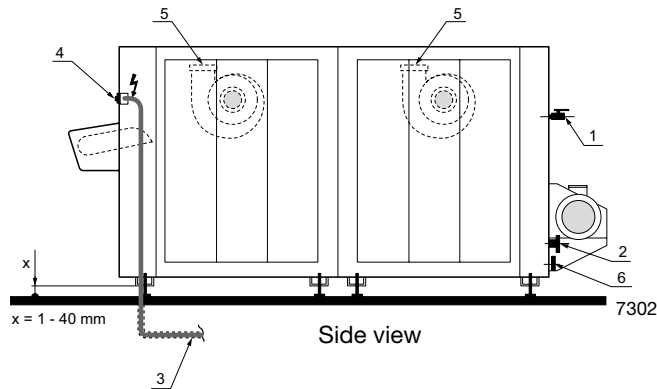

Side view

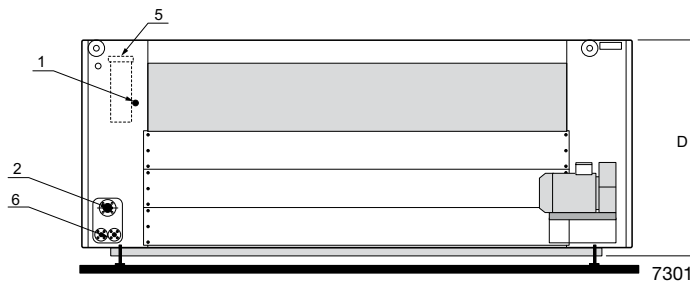

Rear view

- | | |
|-------------------------------|--------------------------------|
| 1 Compressed air inlet | 4 Main switch |
| 2 Steam inlet | 5 Vapor exhaust |
| 3 Electric connection | 6 Condensate connection |