

# Planetary mixers

## XBE40

The XBE40 is an essential item in all kitchens where recipes are prepared using fresh ingredients: preparation of pastry bases, creams, mousses, various sauces or mixtures.



601887

### FEATURES

- This planetary mixer can knead all types of doughs and pastries, mix semi-liquids, emulsions and various sauces.
- Electronic speed variation provides flexibility in the regulations and very precise settings of the parameter.
- Touch button control panel improves the ergonomics and the reliability against the humidity or water jets.
- Control panel equipped with 0-59 minute timer.
- Choice of speeds.
- Splash proof planetary system to avoid water from entering the mechanism.
- Removable safety guard for easy cleaning.
- Height adjustable feet.
- Motor stops when bowl is raised.
- Stainless steel safety guard.
- A kit of wheels is available as optional accessory for easier movement



**Electrolux**

601880, 601881, 601887

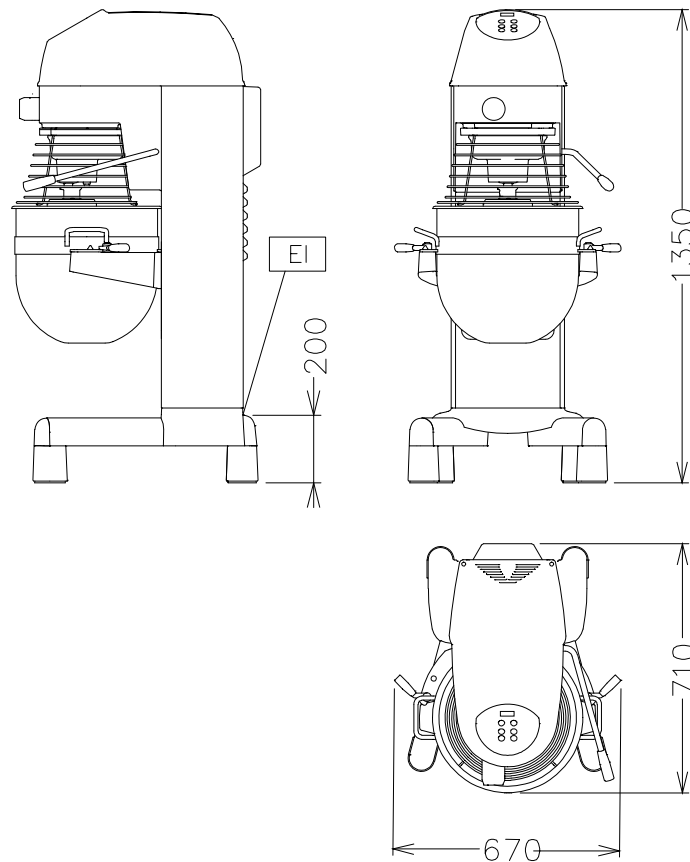

Planetary mixers

XBE40

BDBG010

2010-03-10

Subject to change without notice

	XBEF40S 601880	XBEF40AS 601887	XBEF40SX 601881
<b>LEGEND</b>			
EI - Electrical connection	200...240 V, 1N, 50/60	200...240 V, 1N, 50/60	200...240 V, 1N, 50/60
<b>TECHNICAL DATA</b>			
External dimensions - mm			
width	670	670	670
depth	710	710	710
height	1350	1350	1350
Working capacity - kg of flour			
Choux pastry	6	6	6
Shortcrust pastry	10	10	10
Cold water paste	9	9	9
Sweet pastry	10	10	10
Croissant	8	8	8
Brioche	8	8	8
Meat kg	20	20	20
Puree - kg of potatoes	20	20	20
Power - kW			
installed-electric	1.5	1.5	1.5
Net weight - kg.	113	113	113
Supply voltage	200...240 V, 1N, 50/60	200...240 V, 1N, 50/60	200...240 V, 1N, 50/60
Accessory Hub		●	
Stainless Steel			●
<b>INCLUDED ACCESSORIES</b>			
BOWL FOR 40LT MIXER	1	1	1
DOUGH HOOK FOR 40LT MIXER	1	1	1
PADDLE FOR 40LT MIXER	1	1	1
WHISK FOR 40LT MIXER	1	1	1
<b>ACCESSORIES</b>			
20L BOWL, HOOK, PADDLE, WHISK FOR 40L MIXER	653534	653534	653534
BOWL FOR 40LT MIXER	653525	653525	653525
BOWL TROLLEY-40/60/80LT PLANETARY MIXERS	653585	653585	653585
DOUGH HOOK FOR 40LT MIXER	653523	653523	653523
ELECTRIC HEATING FOR 40L PLANETARY MIXER	653431	653431	653431
FULL PLASTIC SCREEN-XB PLAN.MIXERS 40LT	653704	653704	653704
KIT WHEELS FOR (XB)20/30/40L PLAN.MIXERS	653552	653552	653552
MEATMINCER 70MM-H HUB-ENTERPR.CUT+3DISCS		653016	
PADDLE FOR 40LT MIXER	653524	653524	653524
PLANETARY MIXER 10L-H HUB-DISCONN.DRIVE		653226	
PUREE STRAINER FOR H HUB WITH 3 GRIDS		653187	
S/S MEATMINCER 82MM-H HUB-ENTERPR+1 DISC		653232	
SHARPENING GRINDSTONE FOR H HUB		653062	
VEGETAB.CUTTER H HUB+EJECTOR-DISCONNECT.		653225	
VEGETABLE CUTTER H HUB WITH EJECTOR		653015	
WHISK FOR 40LT MIXER	653522	653522	653522