

Electric Boiling Pans - Smart

The Electrolux electric boiling pans are high benefit solutions, customized to the specific needs like: high capacity, high power, motor tilting, comfortable electronic control, etc.

The range consists of 5 lines : 1 – Easyline pan with electromechanical control, 2- Standardline pans with electromechanical control, 3 - Smartline pan with electronic control, 4- Variomix pans with electronic control and with a variable speed grid stirrer, 5- Promix pans with electronic control and with a variable speed multi purpose impeller. The models detailed on this sheet are electric (steam heated as option) from 50 up to 300 lt with electronically control and with up to 50 food preparation programs.



232172 plus options and accessories

EASY TO USE

- Food is uniformly heated through the base and side walls of the pan by an indirect heating system which uses integrally generated saturated steam at a temperature of 120°C in a jacket with an automatic deaeration system.
- High thermal input and fast heat up.
- Electronic control with possibility to store up to 50 programs, large display for easy use and a complete control over the following functions: start, cooking time, temperature, water filling and mixing speed.
- Motorized tilting.
- Fast reaction, digital display and error-message facility.

- Suitable for connection to a system for monitoring, supervision and recording of all data by means of a computer (as optional accessory).
- The curve of the pan base also allows the appliances to be suitable for small quantities of food.
- Tilting axis is located at the front of the pan to keep the pouring lip high and allows tall vessels to be filled.
- Fast working thanks to the high efficient heating technology and well insulation that keeps the heat inside the well.
- Ergonomic and user friendly thanks to the high tilting position, the well designed pouring lip that makes the filling container operation easy.

- Safe thanks to the high water protection IPX5 and the low temperature outside the panels.
- The electric heating elements are submerged directly in the water of the jacket. The heat losses are minimized and the efficiency of the pan is raised accordingly.
- Safety valve avoids overpressure of the steam in the jacket.
- Safety thermostat prevents from having a dangerously low water level in the jacket.
- Max pressure at 1.0 bar.
- The lid is made of an insulating material which keeps the surface temperature low. There are no removable parts to the lid and it is easy to handle thanks to its light weight.



Electrolux

**Electrolux Industrial Cooking
Electric Boiling Pans - Smart**

EASY TO MAINTAIN

- Constructed to meet the highest hygiene standards.
- AISI 304 stainless steel construction with the deep drawn pan with rounded edges manufactured from AISI 316 stainless steel.
- Vessel can be tilted beyond 90° to completely empty the food.
- Meets the requirements of CE for safety.
- Isolated upper rim avoids risk of the user burning his/herself.

EASY ON THE ENVIRONMENT

- The high-quality thermal insulation of the pan saves energy and keeps operating ambient temperature low.
- 98% recyclable by weight.
- Packing free of toxic substances.

OPTIONS:

- *Automatic water filling - makes it possible to preset the desired quantity of water.*
- *Automatic cooling - allows cooling down of the food connecting the jacket to the tap network.*
- *Food sensor - placed on the bottom of the vessel, it provides efficient temperature control even with small amounts of food. Can be connected to Haccp integrated system.*
- *Spray gun - integrated spray unit.*

(Options must be ordered with the machine and must be installed in the factory)

TECHNICAL DATA	EB500 232172	EB1000 232173	EB1500 232174	EB2000 232175	EB3000 232176
External dimensions - mm					
depth	818	906	906	906	960
height	900	900	900	900	900
Net vessel useful capacity - Lt.	50	100	150	200	300
Working temperature - min/max - °C	30, 121	30, 121	30, 121	30, 121	30, 121
Power - kW					
installed-electric	15	23	30.5	37.5	50
Tilting mechanism	Automatic	Automatic	Automatic	Automatic	Automatic
Bearing	Front	Front	Front	Front	Front
Supply voltage	400 V, 3N, 50	400 V, 3N, 50	400 V, 3N, 50	400 V, 3N, 50	400 V, 3N, 50

**Electrolux Industrial Cooking
Electric Boiling Pans - Smart**

DDE030

2009-07-03

Subject to change without notice

	EB500 232172	EB1000 232173	EB1500 232174	EB2000 232175	EB3000 232176
ACCESSORIES					
BRUSH (LONG) FOR SPRAY UNIT	928083	928083	928083	928083	928083
BRUSH (SHORT) FOR SPRAY UNIT	928082	928082	928082	928082	928082
DISTANCE RING F.CONNECT.(PREV.VERS.PAN)	928049	928049	928049	928049	928049
FASTENING FRAME FOR RIGHT COLUMN 150-300			928036	928036	928036
FASTENING FRAME LEFT COLUMN(FOR BOLTING)	928034	928034	928034	928034	928034
FASTENING FRAME RIGHT COLUMN 50-100L	928035	928035			
FIXTURE 150-300L			928030	928030	928030
FIXTURE 50-100L	928029	928029			
FOUNDATION FRAME LEFT COLUMN	928031	928031	928031	928031	928031
FOUNDATION FRAME RIGHT COLUME 150-300L			928033	928033	928033
FOUNDATION FRAME RIGHT COLUMN 50-100L	928032	928032			
LEFT COLUMN+BEARING,COVER P.F.RIGHT COL.	928023	928023	928023	928023	928023
OPTION AUTOMATIC COOLING 100 LT		928104			
OPTION AUTOMATIC COOLING 150 LT			928105		
OPTION AUTOMATIC COOLING 200 LT				928106	
OPTION AUTOMATIC COOLING 300 LT					928107
OPTION AUTOMATIC COOLING 50 LT	928103				
OPTION AUTOMATIC WATER FILLING	928102	928102	928102	928102	928102
OPTION PROTECTION GRID 100L-VARIO/PROMIX		928096			
OPTION PROTECTION GRID 150L-VARIO/PROMIX			928097		
OPTION PROTECTION GRID 200L-VARIO/PROMIX				928098	
OPTION PROTECTION GRID 300L-VARIO/PROMIX					928099
OPTION PROTECTION GRID 50L-VARIO/PROMIX	928095				
OPTION SPRAY UNIT	928108	928108	928108	928108	928108
STRAINER 100L		928025			
STRAINER 150L			928026		
STRAINER 200L				928027	
STRAINER 300L					928028
STRAINER 50L	928024				
TROLLEY TO STORE TOOLS FOR 2 BOIL. PANS	928044	928044	928044	928044	928044
TROLLEY TO STORE TOOLS FOR 5 BOIL. PANS	928043	928043	928043	928043	928043

Electrolux Industrial Cooking
Electric Boiling Pans - Smart

232172

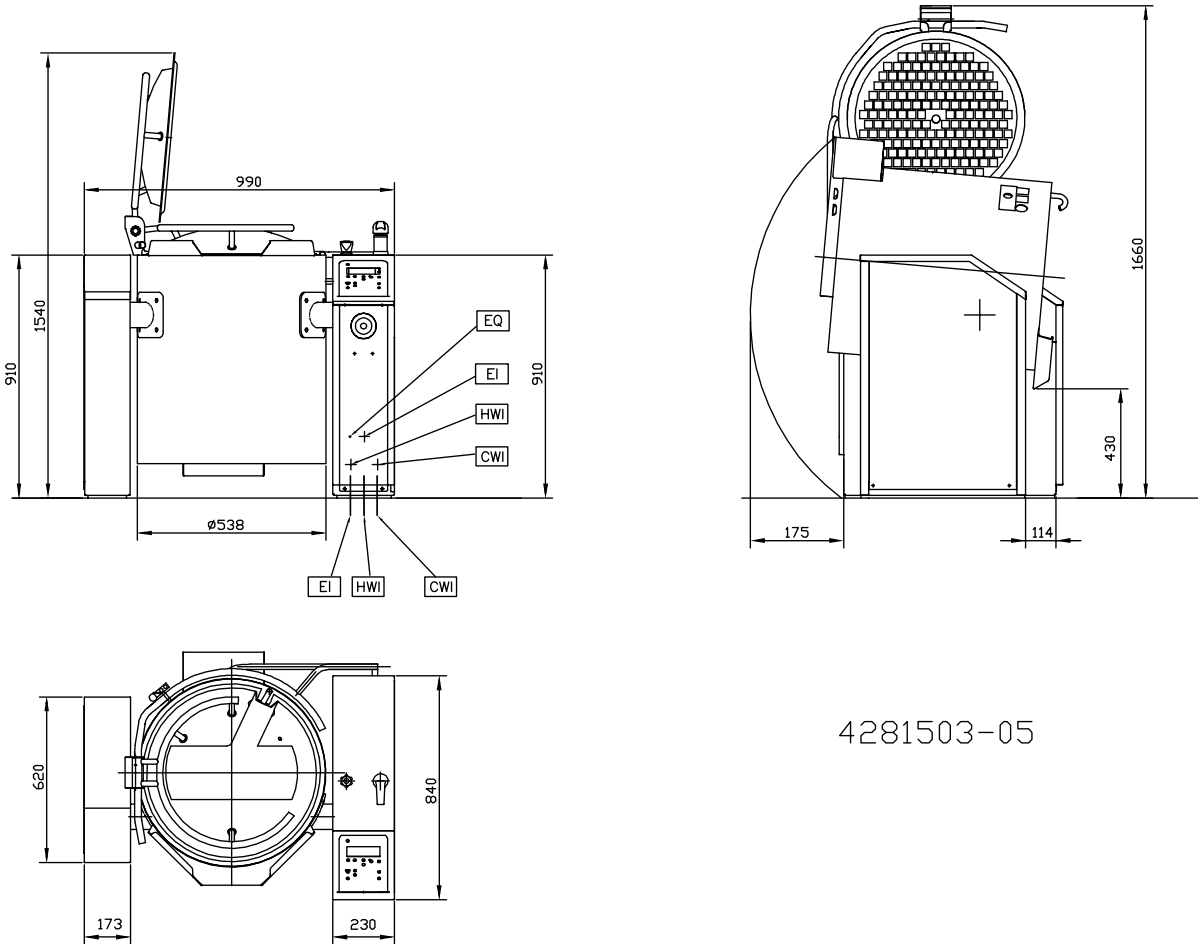

4281503-05

LEGEND CWI - Cold water inlet EI - Electrical connection	EB500 232172
	1/2"
	400 V, 3N, 50

DDE030

2009-07-03

Subject to change without notice

**Electrolux Industrial Cooking
Electric Boiling Pans - Smart**

232173

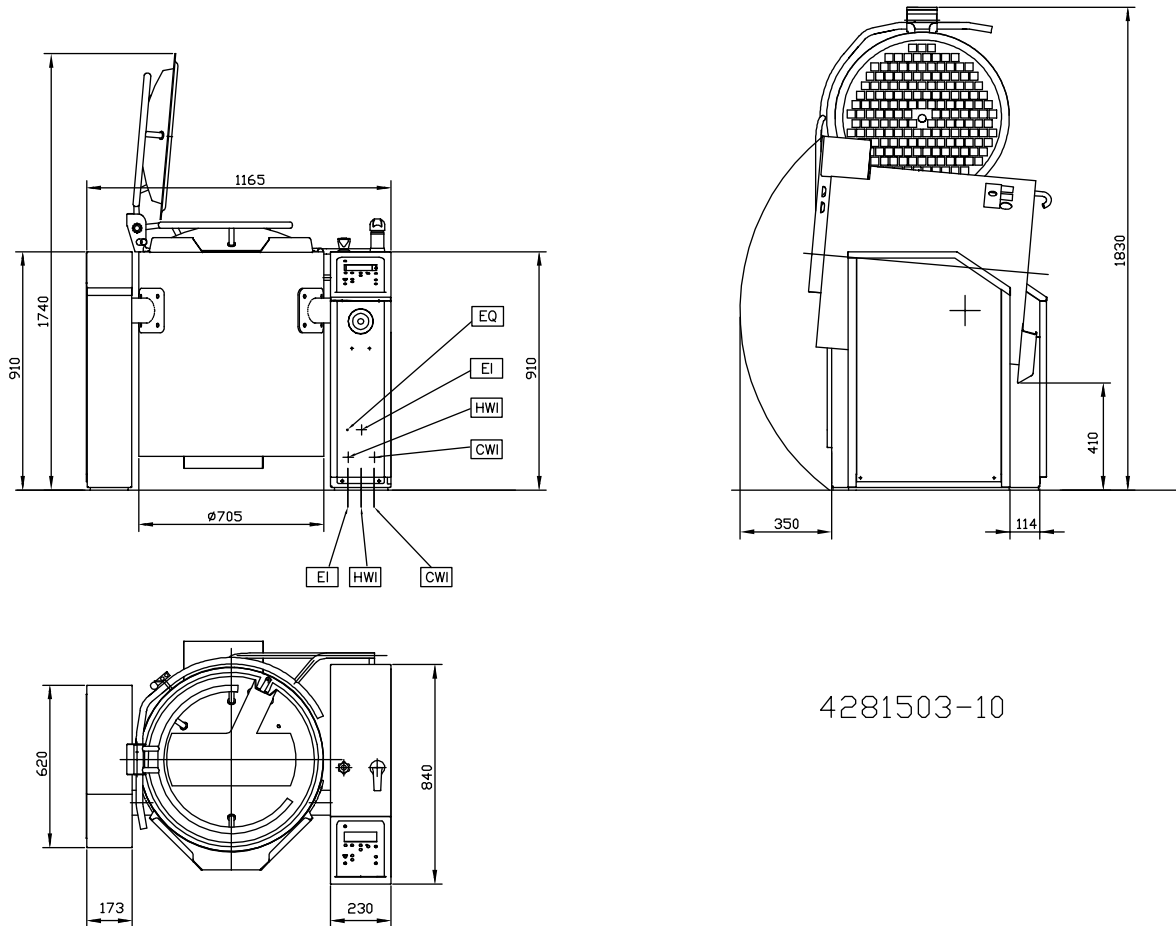

4281503-10

DDE030

2009-07-03

LEGEND CWI - Cold water inlet EI - Electrical connection	EB1000 232173
	1/2"
	400 V, 3N, 50

Subject to change without notice

Electrolux Industrial Cooking
Electric Boiling Pans - Smart

232174

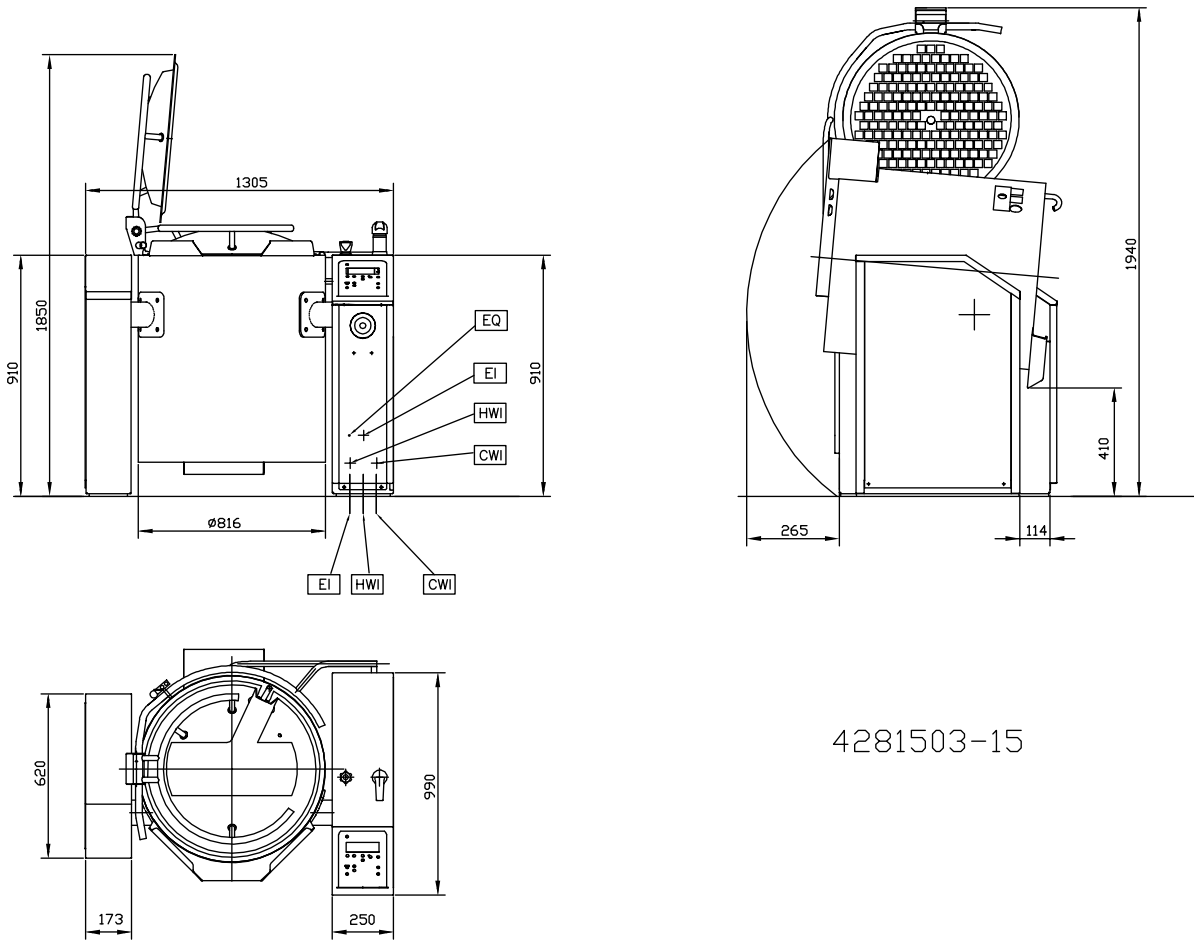

DDE030

2009-07-03

Subject to change without notice

LEGEND CWI - Cold water inlet EI - Electrical connection	EB1500 232174
	1/2"
	400 V, 3N, 50

Electrolux Industrial Cooking
Electric Boiling Pans - Smart

232175

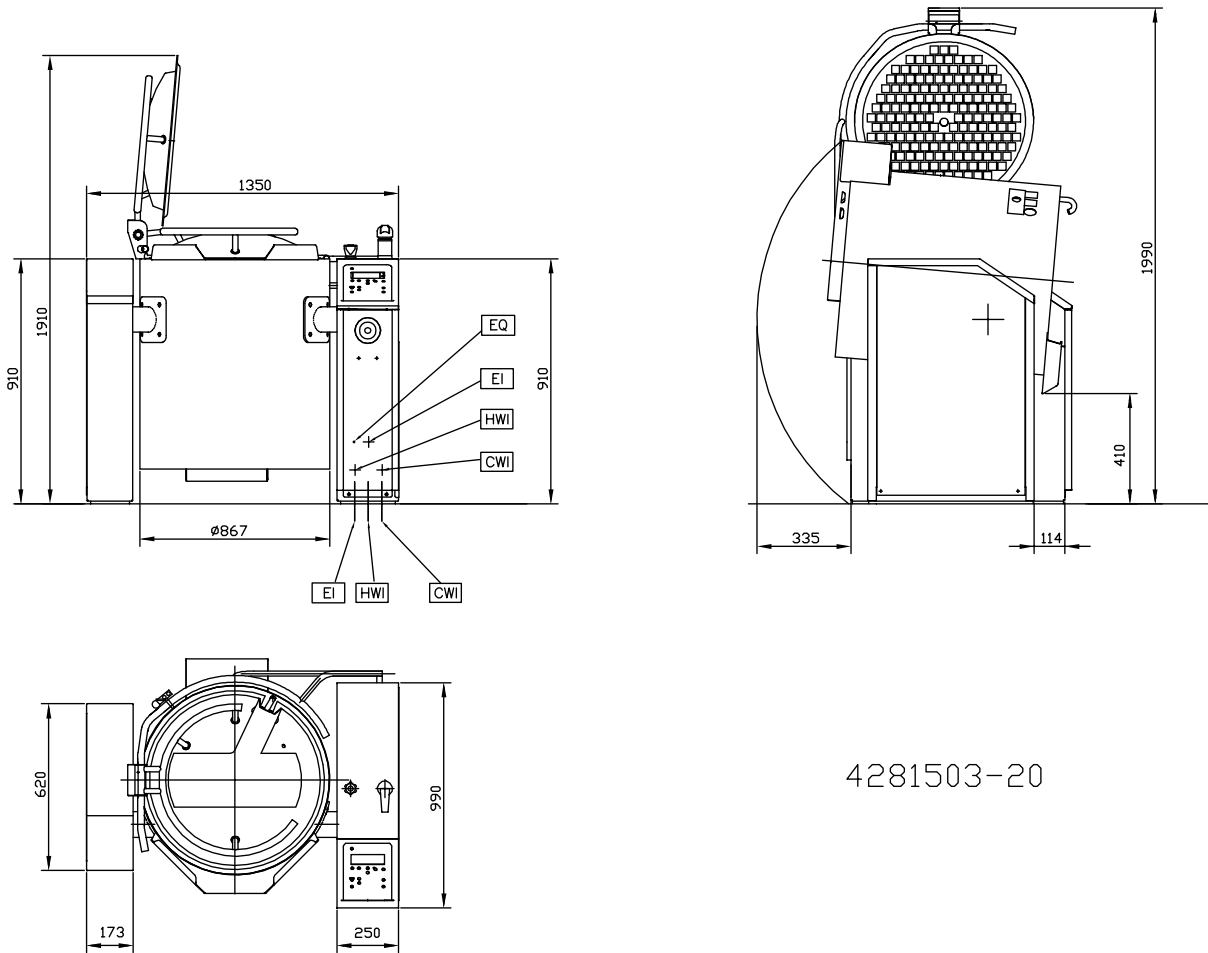

4281503-20

LEGEND CWI - Cold water inlet EI - Electrical connection	EB2000 232175
	1/2"
	400 V, 3N, 50

DDE030

2009-07-03

Subject to change without notice

Electrolux Industrial Cooking
Electric Boiling Pans - Smart

232176

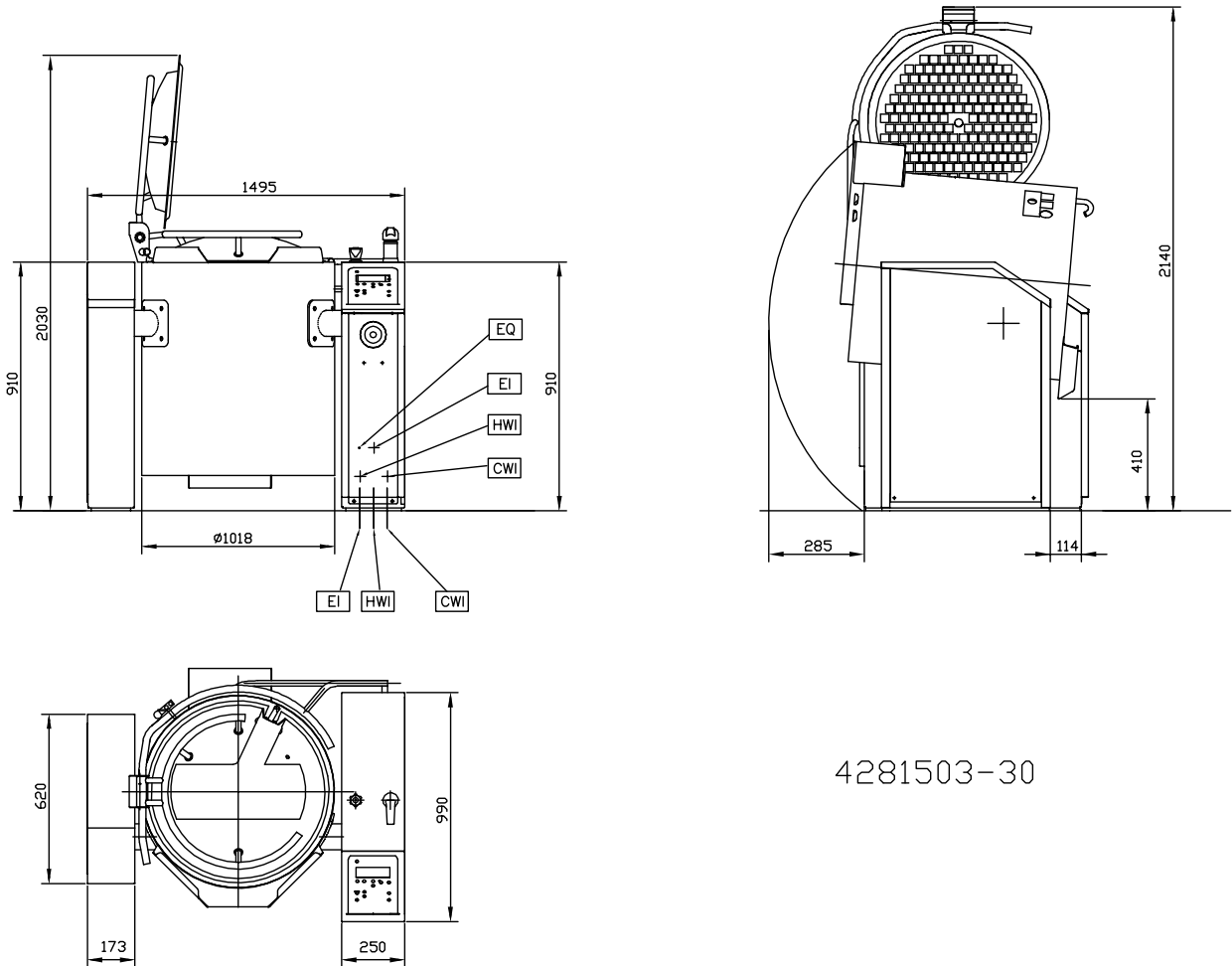

DDE030

2009-07-03

Subject to change without notice

LEGEND CWI - Cold water inlet EI - Electrical connection	EB3000 232176
	1/2"
	400 V, 3N, 50