

Washer extractors

W475S, W485S, W4105S

Features and benefits

- Frequency-controlled motor with fixed wash and extraction speeds ensures smooth action in the wash and extraction sequence
- Good dewatering ability due to higher G-force compared with a traditional solid mount machine
- Solid mount construction with robust frame in galvanized steel
- Available with two types of program controls:
 - Compass Control[®] with:**
 - Large display and one dial for easy program selection
 - Language selection
 - Two Quick Start buttons for frequently used wash programs
 - Wash program packages optimized on *Economy, Performance and Time*
 - Clarus Control[®] with:**
 - Fully programmable microprocessor
 - All relevant wash parameters can be programmed
 - Programming from key pad or downloading via memory card
- AWS – Automatic Weighing System with Compass Control – determine the wash load and adopt the water intake accordingly. Savings on water and energy if machine is not fully loaded
- Extremely low water and energy consumption – see table below
- Four compartment soap box for manual dosing of powder or liquid detergent
- Large door opening for easy loading/unloading
- Stainless and galvanized steel in all vital parts for high degree of rust protection
- SuperBalance™ guarantees the correct extraction force



Compass Control

Images shown are a representation of the product only and variations may occur.



Clarus Control

Main options

- Automatic liquid detergent supply (optional I/O board for Compass Control)
- Stainless steel front panel
- Stainless steel side panel (Clarus Control only)
- Drain pump

Main specifications			W475S		W485S		W4105S	
Max. capacity	kg/lb		8/18		9/20		11/25	
Drum, volume	litre		75		85		105	
diameter	ø mm		520		520		595	
Extraction	rpm		830		830		776	
G-factor			200		200		200	
Heating alternatives, 230/400V	electricity	kW	5.2 / 7.4		5.2 / 7.4		5.2 / 7.4 / 9.6	
	steam		x		x		x	
	non-heated		x		x		x	
Consumption data "Normal 60°C" * (3G01)			El	Steam	El	Steam	El	Steam
Total time	min		46	**	46	**	47	**
Water consumption (cold+hot)	litre		54+14	54+14	55+15	55+15	72+20	72+20
Energy consumption (motor/heating)	kWh		0.15/0.35	0.15	0.15/0.35	0.15	0.15/0.5	0.15
Steam consumption	kg		-	0.5	-	0.5	-	0.7

* Water temperature 15°C cold water and 65°C hot water

** Depending on steam pressure

Electrical connections*			W475S	W485S	W4105S
Heating	Voltage				
El.	230V 1AC 50 Hz	kW(A)	7.3 (35)	7.3 (35)	9.6 (50)
	230V 3AC 50 Hz	kW(A)	7.3 (25)	7.3 (20)	9.6 (35)
	208-240V 3AC 60 Hz	kW(A)	7.3 (25)	7.3 (25)	9.6 (35)
	240V 1AC 60 Hz	kW(A)	5.6 (25)	5.6 (25)	5.6 (25)
	400-415V 3N AC 50 Hz	kW(A)	7.3 (16)	7.4 (16)	9.6 (16)
Steam or non-heated	230V 1AC 60 Hz	kW(A)	0.6 (10)	0.6 (10)	0.8 (10)
	208-240V 1AC 60 Hz	kW(A)	0.6 (10)	0.6 (10)	0.8 (10)
	230V 1AC 50 Hz	kW(A)	0.6 (10)	0.6 (10)	0.8 (10)
Water and steam connection					
Water valves	DN		20	20	20
Water pressure	kPa		200-600	200-600	200-600
Capacity at 300 kPa	l/min		20	20	20
Drain valve	ømm		75	75	75
Draining capacity	l/min		170	170	170
Steam valve	DN		15	15	15
Steam pressure	kPa		300-600	300-600	300-600
Liquid detergent supplies			5	5	5
Floor requirements					
Frequency of the dynamic force	Hz		13.8	13.8	12.9
Floor load at max extraction	kN		1.6 ± 2.4	1.7 ± 2.6	1.9 ± 3.0
Sound levels					
Sound pressure level**	dB(A)		59	59	64
Sound power level (IEC 60704-2-4)	dB(A)		66	66	71
Heat emission					
% of installed power, max			5	5	5
Shipping data					
Shipping volume	net, kg		129	135	145
	crated, kg		150	156	167
	m ³		0.74	0.74	0.9
Accessories					
Steel base frame			x	x	x
Hose kits for water or steam			x	x	x
Fluff collector			x	x	x
Dimensions in mm					
A Width			660	660	720
B Depth			690	730	705
C Height			1115	1115	1200
D			355	355	365
E			725	765	740
F			825	825	910
G			45	45	45
H			1030	1030	1115
I			215	215	215
K			1010	1010	1095
L			130	130	130
M			330	830	910
N			385	385	420
O			100	100	100
P			210	210	235
1 Electrical connection		6 Liquid supply connections			
2 Cold water		7 Control panel			
3 Hot water		8 Soap box			
4 Steam connection		9 Connections for water re-use			
5 Drain		10 Door opening ø 310 mm (W475S, W485S), ø 365 mm (W4105S)			

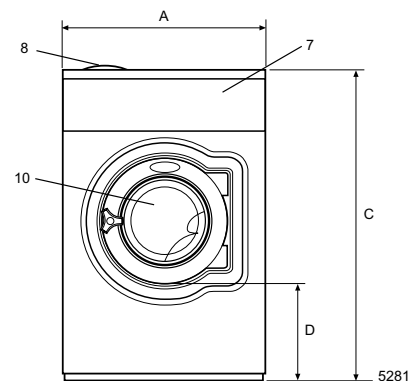

Front

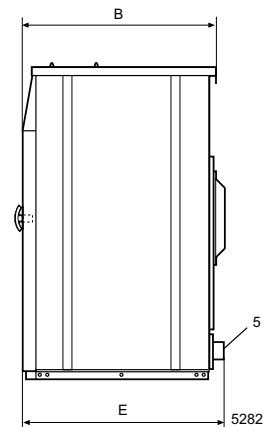

Right side

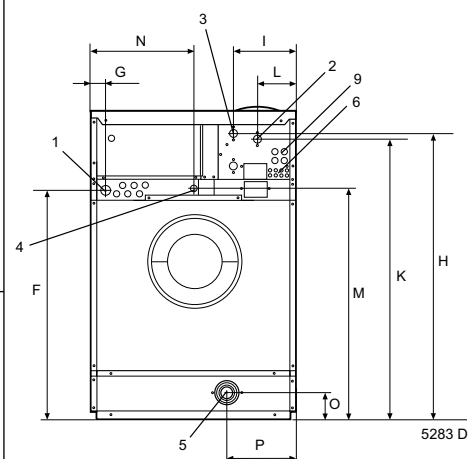

Rear side

Front and side panels in light grey with "Blue Wave" on front panel (RAL 260 70 05, 250 60 30)

* Other voltages available, see installation manual

** Approx. value at operators position in a mid-size laundry room